

Suggested Piping Layout for Glow Boiler
(B85, B120, B160 Series) & Airmax Fan Coil

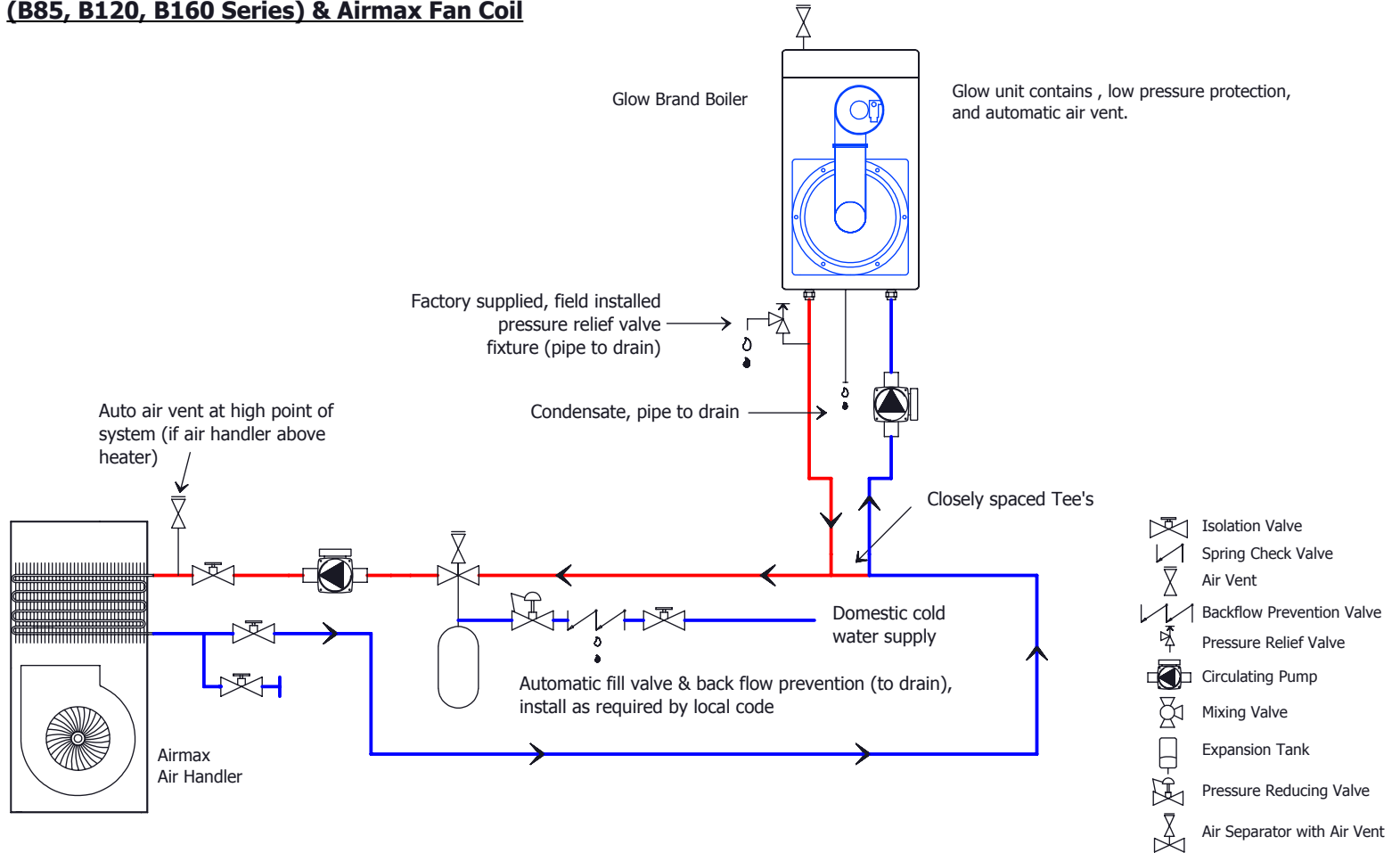

Secondary space heating loop to be sized according to load

This is not an engineering drawing; it is intended only as a guide and not as a replacement for professional engineered drawings. This drawing is not intended to describe a complete system. It is up to the contractor or engineer to determine the necessary components and configurations of the particular system to be installed. This drawing does not imply compliance with local building code requirements. It is the responsibility of the contractor or engineer to ensure that local building code requirements are met.

Suggested Piping Layout for Glow Boiler (B85, B120, B160 Series) & Airmax Fan Coil

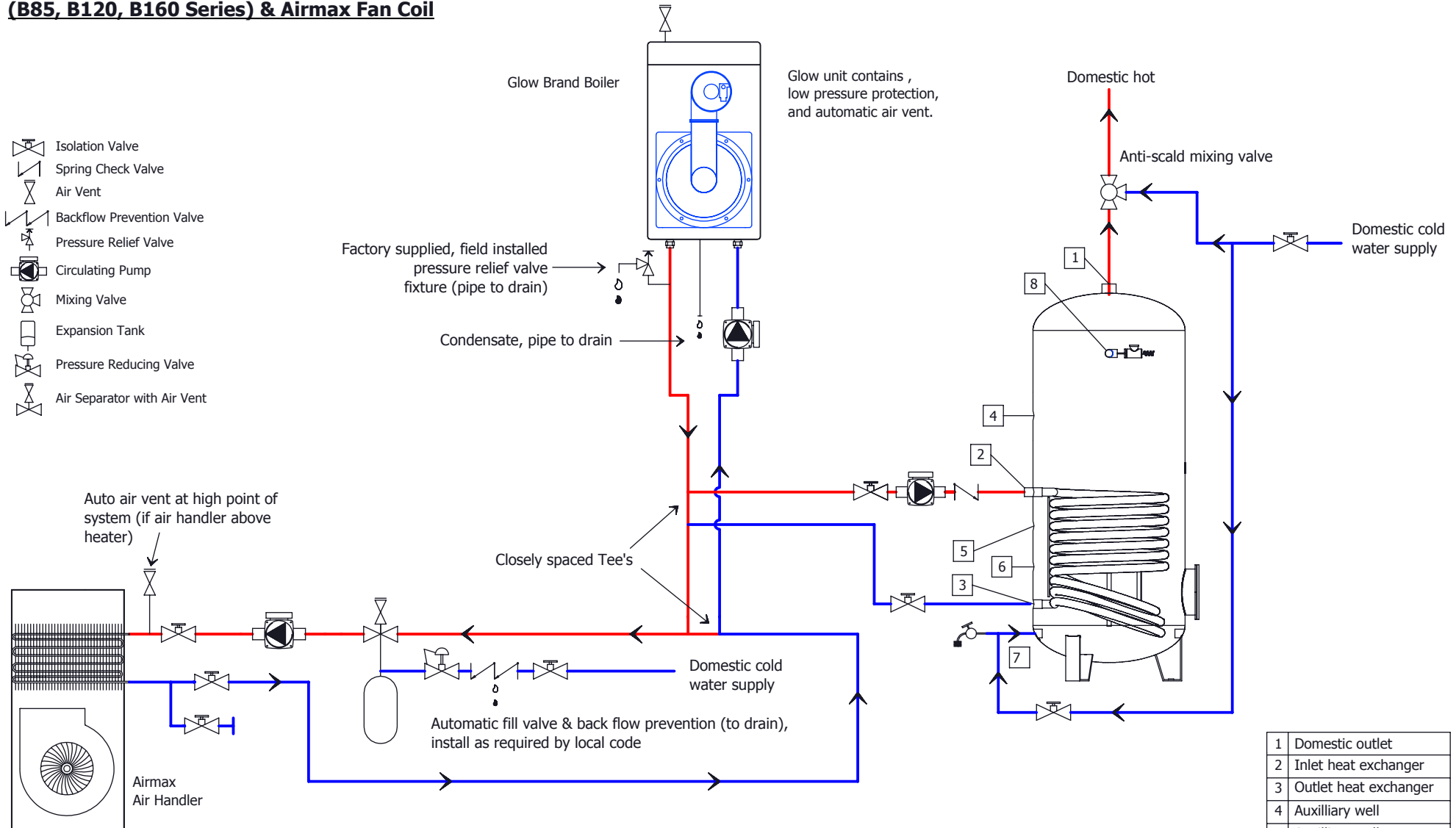

Secondary space heating loop to be sized according to load

This is not an engineering drawing; it is intended only as a guide and not as a replacement for professional engineered drawings. This drawing is not intended to describe a complete system. It is up to the contractor or engineer to determine the necessary components and configurations of the particular system to be installed. This drawing does not imply compliance with local building code requirements. It is the responsibility of the contractor or engineer to ensure that local building code requirements are met.

Suggested Piping Layout for Glow Boiler
(B85, B120, B160 Series) & Infloor Heating

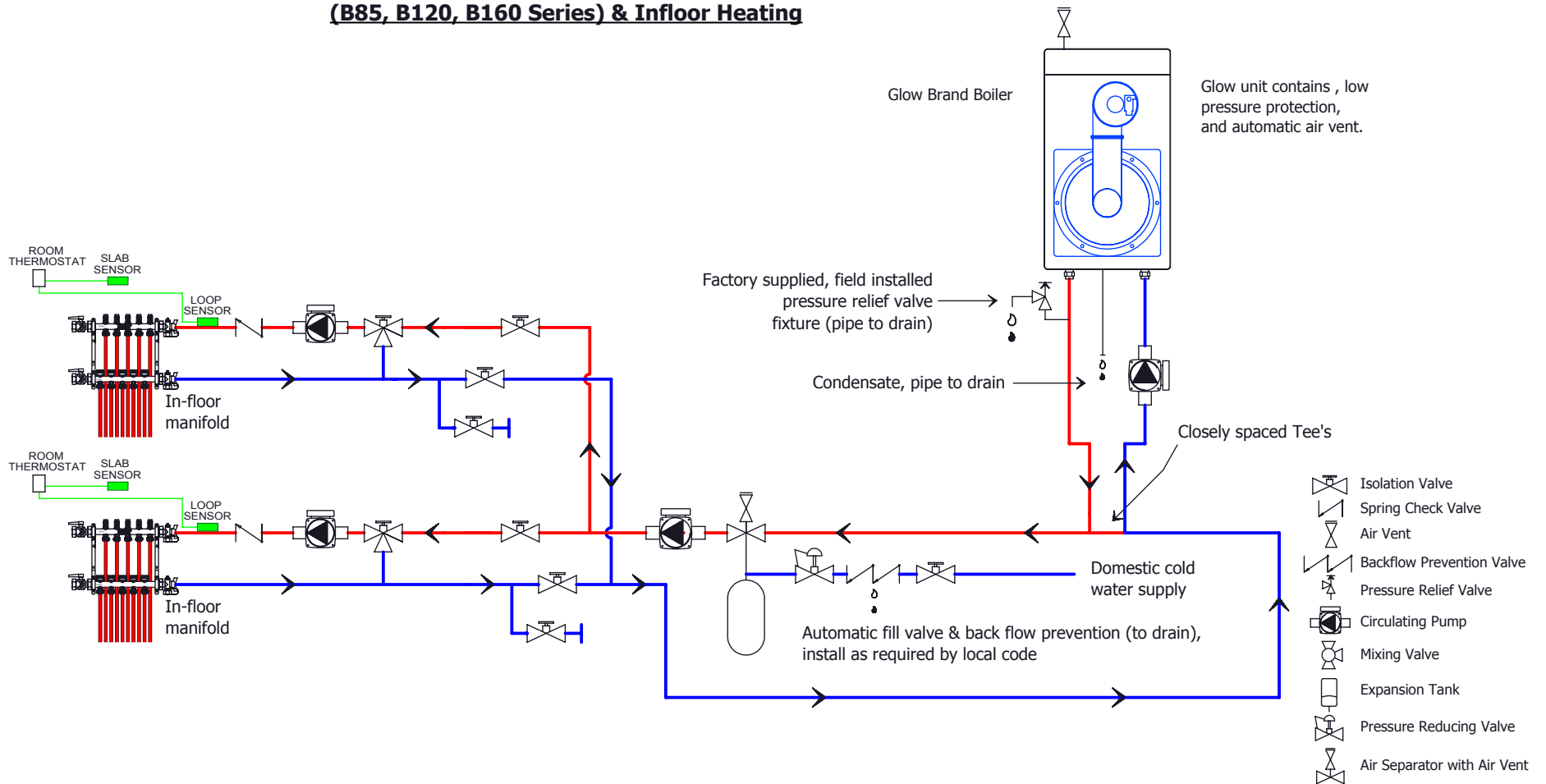

Secondary space heating loop to be sized according to load

This is not an engineering drawing; it is intended only as a guide and not as a replacement for professional engineered drawings. This drawing is not intended to describe a complete system. It is up to the contractor or engineer to determine the necessary components and configurations of the particular system to be installed. This drawing does not imply compliance with local building code requirements. It is the responsibility of the contractor or engineer to ensure that local building code requirements are met.

**Suggested Piping Layout for Glow Boiler
(B85, B120, B160 Series) & Radiators**

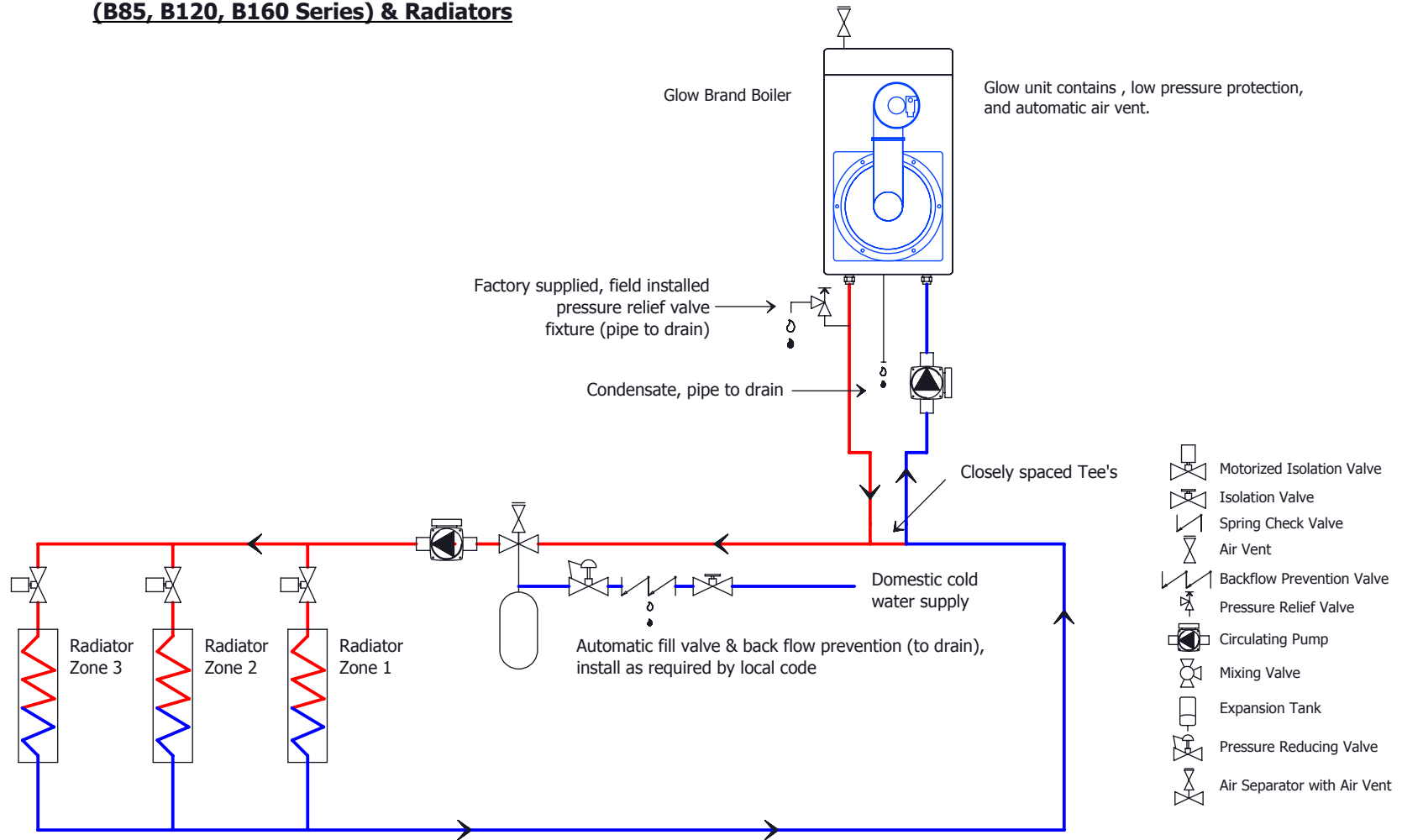

Secondary space heating loop to be sized according to load

This is not an engineering drawing; it is intended only as a guide and not as a replacement for professional engineered drawings. This drawing is not intended to describe a complete system. It is up to the contractor or engineer to determine the necessary components and configurations of the particular system to be installed. This drawing does not imply compliance with local building code requirements. It is the responsibility of the contractor or engineer to ensure that local building code requirements are met.