



# Glow

## Brand™

## Instruction & Installation Manual

*Model*

# Glow T180

*Tankless Condensing Water Heater  
188,000 BTU*



ANSI Z21.10.3 CSA 4.3-2015

**To Installer: Affix this manual adjacent to the appliance.**

**To Consumer: Retain these instructions for future reference**



### WARNING

If the information in these instructions is not followed exactly, a fire or explosion may result, causing property damage, personal injury or death.

Do not store or use gasoline or other flammable vapours and liquids in the vicinity of this or any other appliance.

#### WHAT TO DO IF YOU SMELL GAS

- Do not try to light any appliance.
- Do not touch any electrical switch.
- Do not use any phone in your building.
- Immediately call your gas supplier from a neighbour's phone.
- Follow the gas supplier's instructions.
- If you cannot reach your gas supplier, call the fire department.

Installation and service must be performed by a qualified installer, service agency or the gas supplier.

Glow Brand maintains a continuous improvement policy, specifications are subject to change without notice. We retain the right to alter or modify this product at our discretion.

## Table of Contents

### 1. General Information

1.1 Safety Information	3
1.2 General Warnings	3
1.3 Safety Warnings	5
1.4 Product Conformity	11

### 2. Technical Characteristics

2.1 Technical Data	12
2.2 Dimensions	13
2.3 Unit Performance	14
2.4 Internal Parts Of The Water Heater	15
2.5 Display & Control Circuit Board	16
2.6 User Menu	18
2.7 Service Menu	19
2.8 Installer Section	20

### 3. Installation (Authorized Personnel)

3.1 Reference Standard	22
3.2 Unpacking	22
3.3 Installing The Water Heater	23
3.4 Domestic Hot Water	23
3.5 Recirculation Pump	32
3.6 Water Connections	33
3.7 Gas Connection	36
3.8 Electrical Connections	36
3.9 Venting	38
3.10 Venting Diagrams	40

### 4. Commissioning The Appliance

4.1 General Warnings	46
4.2 Preliminary Operations	46
4.3 Flushing The System	46
4.4 Priming The Condensate Trap	46
4.5 Starting Up The Water Heater	47

4.6 Gas Valve And Set Up	47
--------------------------	----

4.7 Adjusting The Gas Throttle	48
--------------------------------	----

4.8 Set Point Temperature	49
---------------------------	----

### 5. Maintenance (Authorized Personnel)

5.1 General Warnings	50
----------------------	----

5.2 Maintenance	50
-----------------	----

5.3 De-scaling and flushing	50
-----------------------------	----

5.4 Water Heater Inspection	51
-----------------------------	----

5.5 Accessing The Water Heater	52
--------------------------------	----

5.6 Maintenance Operations	52
----------------------------	----

5.7 Gas Supply Connections	55
----------------------------	----

### 6. Lock Out And Warnings

### 7. Troubleshooting

7.1 Ignition Lock-Out	58
-----------------------	----

7.2 High Limit Or Microfuse Open	59
----------------------------------	----

7.3 Flue Gas Temperature Exceeds The Limit	60
--------------------------------------------	----

7.4 Block Flue Switch Open	61
----------------------------	----

7.5 DCW Inlet Sensor Failure	62
------------------------------	----

7.6 Heat Exchanger Outlet Sensor Open	63
---------------------------------------	----

7.7 DHW Sensor Open	64
---------------------	----

7.8 Flue Sensor Open	65
----------------------	----

7.9 No Hot Water	66
------------------	----

7.10 Resistance Value Versus Temperature	67
------------------------------------------	----

### 8. Parts List - Available From Glow Brand

8.1 Cabinet And Interior	68
--------------------------	----

8.2 Water Connections	70
-----------------------	----

8.3 Electrical Connections	75
----------------------------	----



### Warranty and Registration

### Water Heater Commissioning Sheet

## 1. General Information

### 1.1 Safety Information

The following safety symbols are used in this manual. Read and follow all instructions in this manual precisely to avoid unsafe operating conditions, fire, explosion, property damage, personal injury or death.

	<p><b>DANGER</b></p> <p>Indicates an imminently hazardous situation, which, if not avoided, could result in severe injury or death.</p>
	<p><b>WARNING</b></p> <p>Indicates a potentially hazardous situation, which, if not avoided, could result in severe injury or death.</p>
	<p><b>CAUTION</b></p> <p>Indicates a potentially hazardous situation, that, if not avoided could result in property damage.</p>

### 1.2 General Warnings

#### 1.2.1 Installation

- △ Read all safety warnings in the “Instruction & Installation Manual”. The additional safety issues outlined below must also be followed completely when installing this **Glow T180** Tankless Water Heater.
- △ Failure to remove or maintain the area free of combustible material, gasoline and other flammable liquids or vapors can result in severe personal injury, death or substantial property damage.
- △ All applicable local, state, national and provincial codes, ordinances, regulations and laws must be observed.
- △ For installations in Massachusetts – code requires the units to be installed by a licensed plumber or gas fitter.
- △ The appliance cannot operate without the correct amount of air for combustion. Please make sure there is sufficient inflow and outflow of air for ventilation; never obstruct the flow of ventilation air. Failure to provide the proper amount of combustion air can result in a fire or explosion and cause death, serious bodily injury or property damage.
- △ If an external electrical source is utilized, the appliance must be electrically grounded in accordance with local codes or, in the absence of local codes, with the National Electrical Codes ANSI/NFPA 70 and or the CSA C22.1 Canadian Electrical Code.
- △ Follow all local codes and/or the most recent edition of the National Fuel Gas Code (ANSI Z223.1/NFPA 54) in the USA or the Natural Gas and Propane Installation Code in Canada (CAN/CSA B149.1).
- △ This unit is designed for indoor installations. DO NOT operate this unit without the vent piping connected. Exhausted gases must be completely expelled out of the building.
- △ DO NOT use this appliance if any part has been underwater. Immediately call a qualified service technician to inspect and replace any part of the control system and gas control which has been underwater. Be sure not to reverse the water and gas connections as this may damage the gas valve.
- △ Water temperatures over 120°F can cause severe burns instantly or death from scalding. If the proposed water heater outlet temperature is above 120°F, a thermostatically controlled mixing valve (or a temperature limiting valve) for reducing point of use water temperature is recommended to reduce the risk of scald injury. Contact a licensed plumber or the local plumbing authority for further information.
- △ The appliance should be located in an area where leakage within the unit or at its connections will not result in damage to the area adjacent to the appliance or to lower floors of the structure. **Glow Brand** will not be responsible for any damage resulting from leaking if adequate drainage is not provided. When such locations cannot be avoided, it is recommended that a suitable drain pan, adequately drained, be installed under the appliance.
- △ DO NOT use this tankless water heater for any purpose other than water heating and space heating.
- △ The flow of combustion air and ventilation to the water heater must not be obstructed. The water heater area must be kept clear and free from combustible materials, gasoline and other flammable vapors and liquids.
- △ If the water quality is known to be highly acidic and/or extremely hard, water treatments (such as water softeners and filtration) are recommended to maintain full warranty. Consult the local water authority.

- △ DO NOT over-tighten fittings, as pipe and/or fitting damage may occur causing leakage.
- △ DO NOT install the water heater where it is subject to vibrations.
- △ Should overheating occur or the gas supply fails to shut off, turn off the manual gas control valve to the appliance. Contact a Service Technician immediately.
- △ Clearance must be in accordance with the local installation codes and the requirements of the gas supplier.
- △ Never operate the water heater unless it is vented to the outdoors and has adequate air supply to avoid risks of improper operation, fire, explosion or asphyxiation.
- △ DO NOT install this water heater directly on a carpeted floor. A fire hazard may result. The water heater must be installed and adequately supported on a metal or wood panel extending beyond the full width and depth of the water heater by at least 3 inches (76.2mm) in any direction.
- △ For safe operation, an ample supply of air must be provided for proper combustion and ventilation in accordance with the National Fuel Gas Code ANSI Z223.1/NFPA 54 National Fuel Gas Code CSA/B149.1 Natural Gas and Propane Installation Codes or applicable provisions of the local building codes. An insufficient supply of air may result in a yellow, luminous burner flame, carboning or sooting of the heat exchanger, or create a risk of asphyxiation. Do not obstruct the flow of combustion and ventilation air.
- △ This unit is not intended to operate at gas supply pressures other than those shown on the rating plate. Exposure to higher gas supply pressure may cause damage to gas valves, which can result in fire or explosion. If over-pressure has occurred, such as through improper testing of gas lines or emergency malfunction of the supply system, the gas valve must be checked for safe operation.



**A thermostatic mixing valve must be added to this system to prevent scalding, and as per local codes and authorities.**



## 1.2.2 Check The Rating Plate

- △ **Glow T180** water heaters come from the factory configured for use with natural gas or propane. Prior to installation, check the rating plate of the water heater to ensure the unit matches gas type, gas pressure, water pressure and electrical supply. If the unit does not match the requirements, do not install.

- △ There is a risk in using fuel burning appliances in rooms or areas where gasoline, other flammable liquids or gas engine equipment or vehicles are stored, operate or are repaired. Flammable vapors are heavy and travel along the floor and may be ignited by the igniter or main burner flames causing fire or explosion. Some local codes permit operation of gas appliances if installed 18 inches or more above the floor. Flammable items, pressurized containers or any other potential fire hazardous articles must never be placed on or adjacent to the water heater. Open containers of flammable materials should not be stored or used in the same room with the water heater.
- △ DO NOT install the **Glow T180** water heater in areas with excessive high humidity.
- △ DO NOT install the unit in locations where there is excessive humidity, such as a bathroom, damp crawl space and other areas with high levels of humidity. This may cause the unit to malfunction.
- △ To avoid possible electrical shock, DO NOT touch the internal components of the water heater or the power cord with wet hands.
- △ DO NOT splash excessive water on the water heater when cleaning, as it is water resistant, not water proof.
- △ Professionally qualified personnel in accordance with current laws and standards and in line with the manufacturer's instructions must install the appliance.
- △ The commissioning of the water heater and any subsequent works carried out on the appliance must be performed by an appropriately qualified technician.
- △ The appliance must be used solely for the purpose for which it has been designed and manufactured: Domestic hot water production and central heating if applicable (maximum set point of 63°C/145°F). Any other use is deemed as improper and as such dangerous. Under no circumstances will the manufacturer be held responsible for damage or injury to persons or animals caused by errors in the installation and/or use of the appliance, or through non-compliance with current local and national standards and/or the manufacturer's instructions.
- △ The installation, operation and maintenance manual are an integral and essential part of the product and must be kept with the appliance always.
- △ The warnings contained in this chapter have been written for the appliance user, the installer and the service technician.

 **Do not attempt to interfere with the appliance in any way.**

- Δ As dictated by current legislation, this appliance must be installed exclusively by qualified and certified personnel. Before starting the water heater for the first time, make sure that it is connected to a water supply and central heating system (maximum set point of 63°C/145°F) compatible with its performance characteristics.
- Δ Prior to start-up, the water pipes should be flushed to remove any residues that could compromise the operation of the appliance.
- Δ The electrical supply must be checked by a qualified electrician to ensure that it can support the maximum power absorption of the appliance, as indicated on the appliance rating plate. In particular, make sure that the wire ratings are adequate for the power being used.
- Δ Do not use adapters, multiple sockets or extension cords to connect the appliance to the power supply.
- Δ The appliance must be plugged into a 120v wall receptacle in accordance with the current wiring regulations.
- Δ If the wires are damaged in any way, switch off the appliance and have the wire replaced by a qualified technician.
- Δ When the appliance is no longer required for use, unplug the unit from the wall receptacle and draw water from the unit.

 **Chapters 3, 4, & 5 of this manual must be read carefully as they provide information on the installation, commissioning and maintenance of the appliance.**

- Δ After the removal of all the packaging, check that the appliance has not been damaged. In case of doubt, do not attempt to use the product but refer to the supplier. Packing materials (cardboard box, staples, plastic bags, polystyrene, etc.) must not be left within reach of children in that these items represent a potential hazard and must be disposed of in a responsible manner.
- Δ Before carrying out any cleaning or maintenance operations, disconnect the appliance from the main electrical supply by unplugging the unit from the wall.
- Δ In the case of a fault and/or malfunction in the appliance, shut down the system. Do not interfere with or attempt any repairs. Call for professionally qualified technical assistance.

- Δ Any warranty repairs to the appliance must be carried out exclusively by the manufacturer's authorized trained service dealers using original parts. Non-compliance with the above requirements may compromise the safety of the appliance and invalidate the warranty. In order to guarantee the efficiency of the appliance and its correct operation, it must be serviced regularly by professionally qualified personnel in line with the manufacturer's instructions.
- Δ Only original accessories or optional extras (including electrical parts) must be used with the appliance.
- Δ Should there be a smell of gas present in the room where the appliance is installed, **DO NOT** attempt to activate any electric switches, telephones or any other equipment that may cause sparks. Open doors and windows immediately to create a current of air and ventilate the room. Shut-off the main gas supply valve (at the meter), or on the cylinder in the case of propane gas, and call an authorized service contractor.

### 1.3 Safety Warnings



#### Carbon Monoxide Detectors

Many jurisdictions require the installation of carbon monoxide detectors in buildings where a side wall vented fuel burning appliance is installed. Installers must abide by local code requirements regarding the installation of CO detectors. The use of a certified carbon monoxide detector is recommended but not required by **Glow Brand**.

### “In the State of Massachusetts only”

For all horizontally vented gas fueled equipment installed in every dwelling, building or structure used in whole or in part for residential purposes, including those owned and operated by the Commonwealth and where the side wall exhaust vent termination is less than seven (7) feet above finished grade in the area of the venting, including but not limited to decks and porches, the following requirements shall be satisfied:

1. **INSTALLATION OF CARBON MONOXIDE DETECTORS.** At the time of installation of the side wall horizontal vented gas fueled equipment, the installing plumber or gas fitter shall observe that a hard wired carbon monoxide detector with an alarm and battery back-up is installed on the floor level where the gas equipment is to be installed and on each additional level of the dwelling, building or structure served by the equipment. It shall be the responsibility of the property owner to secure the services of qualified licensed professionals for the installation of hard wired carbon monoxide detectors.

a. In the event that the side wall horizontally vented gas fueled equipment is installed in a crawl space or an attic, the hard wired carbon monoxide detector with alarm and battery back-up may be installed on the next adjacent floor level.

b. In the event that the requirements of this subdivision cannot be met at the time of completion of installation, the owner shall have a period of 30 days to comply with the above requirements, provided, however, that during said 30 day period a battery operated carbon monoxide detector with alarm shall be installed.

2. **APPROVED CARBON MONOXIDE DETECTORS.** Each carbon monoxide detector as required in accordance with the above provisions shall comply with NFPA 720 and be ANSI/UL 2034 listed and IAS certified.

3. **SIGNAGE.** A metal or plastic identification plate shall be permanently mounted to the exterior of the building at a minimum height of eight (8) feet above grade directly in line with the exhaust vent terminal for the horizontally vented gas fueled heating appliance or equipment. The sign shall read, in print size no less than one-half (1/2) inch in size, “GAS VENT DIRECTLY BELOW. KEEP CLEAR OF ALL OBSTRUCTIONS”.

4. **INSPECTION.** The state or local gas inspector of the side wall horizontally vented gas fueled equipment shall not approve the installation unless, upon inspection, the inspector observes carbon monoxide detectors and signage installed in accordance with the provisions of 248 CMR 5.08(2)(a) 1 through 4.

#### **Notice prior to installation**

This appliance must be installed by a licensed professional in accordance with the Massachusetts Plumbing and Fuel Gas Code 248 CMR Sections 2.00 and 5.00.

If you are not properly training, you must not install this unit.



**FOR YOUR SAFETY READ BEFORE OPERATING**

**WARNING:** If you do not follow these instructions exactly, a fire or explosion may result causing property damage, personal injury or loss of life

- |                                                                                                                                                                                                                                                                                                                                                                                                                                                                                                                                                                                         |                                                                                                                                                                                                                                                                                                                                                                                                                                                                                                                                                                                                                                                                                                                                  |
|-----------------------------------------------------------------------------------------------------------------------------------------------------------------------------------------------------------------------------------------------------------------------------------------------------------------------------------------------------------------------------------------------------------------------------------------------------------------------------------------------------------------------------------------------------------------------------------------|----------------------------------------------------------------------------------------------------------------------------------------------------------------------------------------------------------------------------------------------------------------------------------------------------------------------------------------------------------------------------------------------------------------------------------------------------------------------------------------------------------------------------------------------------------------------------------------------------------------------------------------------------------------------------------------------------------------------------------|
| <p>A. This appliance does not have a pilot. It is equipped with a direct ignition device, which automatically lights the burner. Do not try to light the burner by hand.</p> <p>B. <b>BEFORE OPERATING:</b> Smell all around the appliance area for gas. Be sure to smell next to the floor because some gas is heavier than air and will settle on the floor.</p> <p><b>WHAT TO DO IF YOU SMELL GAS</b></p> <ul style="list-style-type: none"> <li>• Do not try to light any appliance.</li> <li>• Do not touch and electric switch: do not use any phone in your building.</li> </ul> | <p>C. Use only your hand to push in or turn the gas control knob. Never use tools. If the remote keypad doesn't work, do not try to repair it, call a qualified service technician. Forced or improper repair may result in fire or explosion.</p> <p>D. Do not use this appliance if any part has been under water. Immediately call a qualified service technician to inspect the appliance and to replace any part of the control system and any gas control which has been under water.</p> <ul style="list-style-type: none"> <li>• Immediately call your gas supplier from a neighbor phone. Follow the gas supplier's instructions.</li> <li>• If you cannot reach your gas supplier, call the fire department</li> </ul> |
|-----------------------------------------------------------------------------------------------------------------------------------------------------------------------------------------------------------------------------------------------------------------------------------------------------------------------------------------------------------------------------------------------------------------------------------------------------------------------------------------------------------------------------------------------------------------------------------------|----------------------------------------------------------------------------------------------------------------------------------------------------------------------------------------------------------------------------------------------------------------------------------------------------------------------------------------------------------------------------------------------------------------------------------------------------------------------------------------------------------------------------------------------------------------------------------------------------------------------------------------------------------------------------------------------------------------------------------|

**OPERATING INSTRUCTIONS**

- |                                                                                                                                                                                                                                                                                                                                                                                                                                                                                                                     |                                                                                                                                                                                                                                                                                                                                                                                                                                                                                                                                                                                                                          |
|---------------------------------------------------------------------------------------------------------------------------------------------------------------------------------------------------------------------------------------------------------------------------------------------------------------------------------------------------------------------------------------------------------------------------------------------------------------------------------------------------------------------|--------------------------------------------------------------------------------------------------------------------------------------------------------------------------------------------------------------------------------------------------------------------------------------------------------------------------------------------------------------------------------------------------------------------------------------------------------------------------------------------------------------------------------------------------------------------------------------------------------------------------|
| <ol style="list-style-type: none"> <li>1. <b>STOP!</b> Read the safety information above before proceeding.</li> <li>2. Set the thermostat to the lowest setting.</li> <li>3. Turn off all power to the electrical appliance.</li> <li>4. This appliance does not have a pilot. It is equipped with a direct ignition device, which automatically lights the burner. Do not to light the burner by hand.</li> <li>5. Turn the manual valve located at the gas inlet of the appliance clockwise  to "OFF"</li> </ol> | <ol style="list-style-type: none"> <li>6. Wait (5) minutes to clear out any gas. If you then smell gas, <b>STOP!</b> Follow (B) in the safety information above this label. If you don't smell gas, go to next step.</li> <li>7. Turn the manual valve located at the gas inlet of appliance counterclockwise to  "ON" (see Figure 47.).</li> <li>8. Turn on all electric power to the appliance.</li> <li>9. Set the thermostat to desired setting.</li> <li>10. If the appliance will not operate, follow the instructions "To Turn Off Gas To Appliance" and call your service technician or gas supplier.</li> </ol> |
|---------------------------------------------------------------------------------------------------------------------------------------------------------------------------------------------------------------------------------------------------------------------------------------------------------------------------------------------------------------------------------------------------------------------------------------------------------------------------------------------------------------------|--------------------------------------------------------------------------------------------------------------------------------------------------------------------------------------------------------------------------------------------------------------------------------------------------------------------------------------------------------------------------------------------------------------------------------------------------------------------------------------------------------------------------------------------------------------------------------------------------------------------------|

**TO TURN OFF GAS TO THE APPLIANCE**

- |                                                                                                                                                                                        |                                                                                                                                           |
|----------------------------------------------------------------------------------------------------------------------------------------------------------------------------------------|-------------------------------------------------------------------------------------------------------------------------------------------|
| <ol style="list-style-type: none"> <li>1. Set the thermostat to the lowest setting.</li> <li>2. Turn off all electric power to the appliance if service is to be performed.</li> </ol> | <ol style="list-style-type: none"> <li>3. Turn the manual valve at gas inlet of appliance clockwise to  "OFF" (see figure 47).</li> </ol> |
|----------------------------------------------------------------------------------------------------------------------------------------------------------------------------------------|-------------------------------------------------------------------------------------------------------------------------------------------|

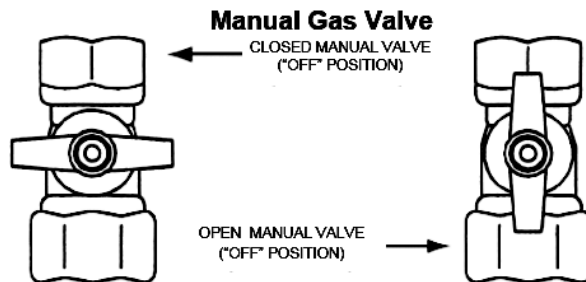



# WARNING

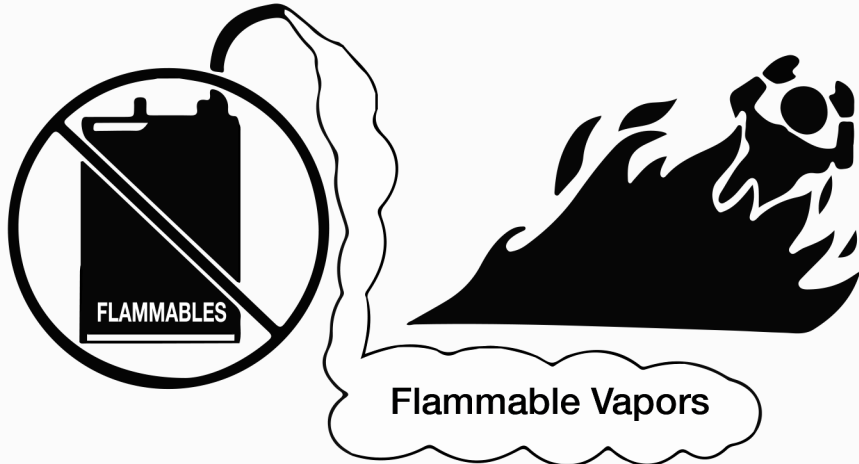

## FIRE AND EXPLOSION HAZARD



Can result in serious injury or death

Do not store or use gasoline or other flammable vapors and liquids in the vicinity of this or any other appliance. Storage of or use of gasoline or other flammable vapors or liquids in the vicinity of this or any other appliance can result in serious injury or death.

Vapors from flammable liquids can explode and catch fire causing death or severe burns.

Do not use or store flammable products such as gasoline, solvents or adhesives in the same room or area near this appliance, or any other appliance or any possible ignition source.

Keep flammable products:

Vapors:

1. far from any possible ignition source,
2. in approved containers
3. tightly closed and
4. out of children's reach

1. cannot be seen,
2. are heavier than air
3. go a long way on the floor
4. can be carried away from other rooms to possible ignition sources by air currents

Water heaters in residential garages must be installed and located, or protected, to avoid physical damage.

Read and follow water heater warnings and instructions. If owner's manual is missing contact the distributor or manufacturer.





# WARNING

If the information in these instructions is not followed exactly, a fire or explosion may result, causing property damage, personal injury or death.

Do not store or use gasoline or other flammable vapours and liquids in the vicinity of this or any other appliance.

#### **WHAT TO DO IF YOU SMELL GAS**

Do not try to light any appliance.

Do not touch any electrical switch; do not use any phone in your building.

Immediately call your gas supplier from a neighbour's phone.

Follow the gas supplier's Instructions.

If you cannot reach your gas supplier, call the fire department.

**Installation and service must be performed by a qualified installer, service agency or the gas supplier.**

Minimum clearances from combustible construction.

0-inches sides, 0-Inches back. 0- inches top.

For closet installation, 0-inches front or for alcove installation.

This water heater is provided with a pressure relief valve, for safe operation of the water heater, the relief valve(s) must not be removed from its designated point of installation or plugged.

The pressure relief valve provided by the manufacturer shall be installed at the time of installation of the heater in the location specified by the manufacturer. Local codes shall govern installation of relief devices.

#### **"Warning"**

"This appliance must be installed in accordance with the local codes or, in the absence of local codes, the National Fuel Gas Code, ANSI Z223.1/NFPA 54 or the CSA B149.1, Natural Gas and Propane Installation Code".

#### **SUITABLE FOR COMBINATION WATER (POTABLE) HEATING**

and space heating and not suitable for space heating applications only.

Toxic chemicals, such as used for boiler treatment, shall not be introduced into potable water heater used for space heating. This water heater may never be connected to any existing heating system or component(s) previously used with a non potable water heating appliance.

**"For operation at outlet water temperatures not in excess of 145°F (63°C)"**



# DANGER

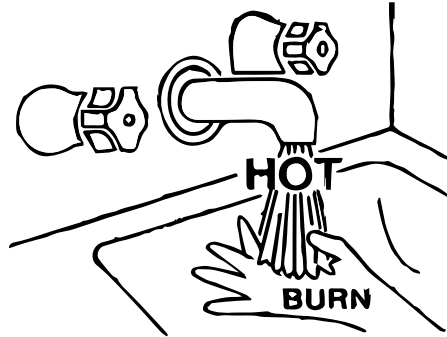

The temperature at which injury occurs varies with the person's age and time of exposure. Water temperature over 125°F/52°C can cause severe burns instantly or death from scalding.

The slower response time of disabled persons increases the hazards to them. Never allow small children to use a hot water tap, or to draw their own bath water. Never leave a child or disabled person unattended in a bathtub or shower.

The water heater should be located in an area where the general public does not have access to the temperature control.

Lower water temperatures should be used to avoid the risk of scalding. It is further recommended, in all cases, that the water temperature be set for the lowest temperature which satisfies the user's hot water needs. This will also provide the most energy efficient operation of the water heater and minimize scale formation in the heat exchanger, thus prolonging the life of the unit.

Setting the water heater temperature at 120°F/49°C will reduce the risk of scalds. Some locations require settings at specific lower temperatures. The table below shows the approximate time-to-burn relationship for normal adult skin.

Hot water temperatures required for automatic dishwasher and laundry use can cause scalds and burns resulting in serious personal injury and/or death.

**Table - Risks of Scalds**

Temperature Setting	Time to Produce 2nd, 3rd Degree Burns on Adult Skin
Over 170°F/77°C	Nearly instantaneous
160°F/71°C	About 1/2 second
150°F/66°C	About 1-1/2 seconds
140°F/60°C	Less than 5 seconds
130°F/54°C	About 30 seconds
120°F/49°C or less	More than 5 minutes

To protect against injury, you must install a tempering valve in the water system. This valve will reduce point of discharge temperature by mixing cold and hot water in branch supply lines. Such valves are available from the local plumbing supplier.

## 1.4 Product Conformity

All **Glow T180** Tankless Water Heaters are ETL certified and possess technical and functional characteristics that comply with the following standards:

American National Standard/CSA Standard for Gas Water Heaters Volume III, Storage Water Heaters with input Ratings above 75,000 Btu per Hour, Circulating and Instantaneous. Conforms to ANSI STD Z21.10.3, certified to CSA STD 4.3-2015.

The materials used, such as copper, brass, stainless steel, etc. form a compact, homogeneous, highly functional unit that is easy to install and simple to operate. In its simplicity, the wall-mounted appliance is equipped with all the appropriate accessories required to make it a fully independent water heater capable of satisfying domestic hot water production and central heating (maximum set point of 63°C/145°F) needs if installed. All water heaters are fully inspected. This manual must be kept in a safe place and must accompany the water heater at all times.

**Glow Brand** will not be held responsible for any misinterpretation of this manual.

**Glow Brand** will not be held responsible for the consequences in the case of non-observance of the instructions contained in this manual or in the case where actions not specifically described herein are undertaken.

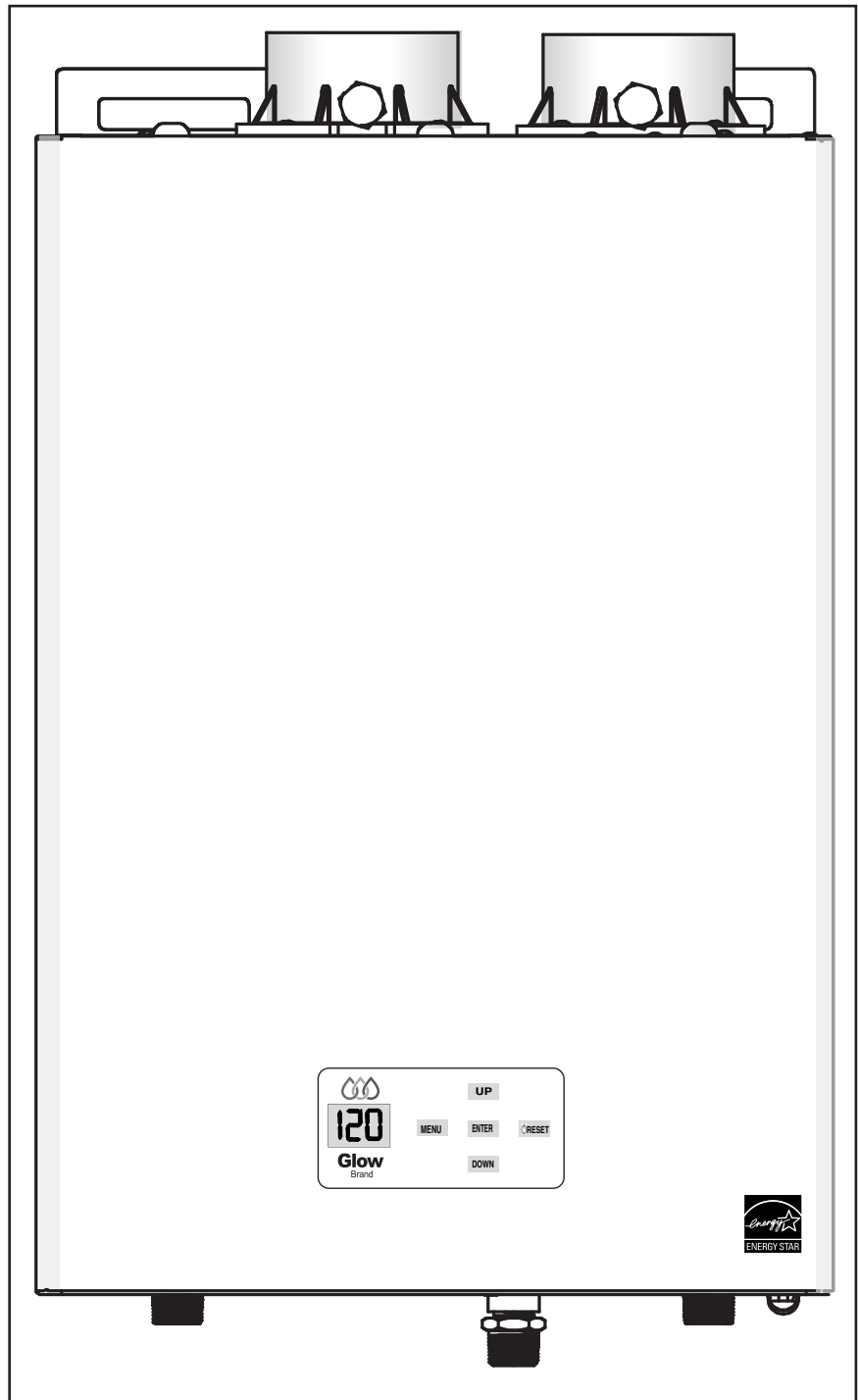

Figure 1.1 - Glow T180

**2. Technical Characteristics**

**2.1 Technical Data**

<b>Glow T180</b>		<b>Natural Gas</b>	<b>Propane</b>
Heat Input (Max)	Btuh (kW)	194,000 (56.8)	194,000 (56.8)
Heat Input (Min)	Btuh (kW)	20,500 (6.0)	20,500 (6.0)
Energy Factor (EF)		97%	95%
Unified Energy Factor (UEF)		95%	93%

**Domestic Hot Water**

Heat Output (Max)	Btuh (kW)	188,000 (55.1)	188,000 (55.1)
Hot Water Temperature Setting (min-max)	°F (°C)	102-145 (39-63)	
Maximum Water Pressure	Psig (bar)	150 (10.3)	
Minimum Water Pressure	Psig (bar)	30 (2.1)	
DHW Flow at ΔT 35°F	usgpm (lpm)	10.7 (40.2)	
DHW Flow at ΔT 45°F	usgpm (lpm)	8.4 (31.8)	
DHW Flow at ΔT 72°F	usgpm (lpm)	5.2 (19.7)	
DHW Flow at ΔT 77°F	usgpm (lpm)	4.9 (18.6)	
Minimum Activation Flow Rate	usgpm (lpm)	0.6 (2.27)	

**Dimensions (casing size)**

Width	In (mm)	16 ¾ (425)
Height	In (mm)	24 ⅝ (619)
Depth	In (mm)	17 ¼ (438)
Weight (NET)	Lbs (Kg)	86 (39)
Weight (GROSS)	Lbs (Kg)	90 (41)

**Connections**

Cold Water In	MPT	¾"
Hot Water Out	MPT	¾"
Gas Inlet Connection	MPT	¾"

**Gas Supply**

Inlet Pressure (min-max)	inch. wc.	3.5-10	8-13
Gas Valve Outlet Pressure	inch. wc.	-0.03	-0.03

**Electrical Specification**

Power Supply	V/Hz	120/60
Electrical Power Consumption	W	119

**General**

Installation Type		Indoor Wall Hung
Venting Type		Forced Draft Direct Vent
Ignition		Electronic Ignition

**Venting**

Exhaust	inch	2, 2 ½, 3 in PVC, CPVC
Intake	inch	2, 2 ½, 3 in PVC, CPVC, ABS
Vent Clearances	inch	0 in to combustibles
Safety Devices	Ionization Electrode, Ignition Software, Water Temperature Sensors, Flue Temperature Sensor and Fuse, High Limit Switch, Blocked Flue Switch & Power Fuse.	

Table 2.1

**2.2 Dimensions**

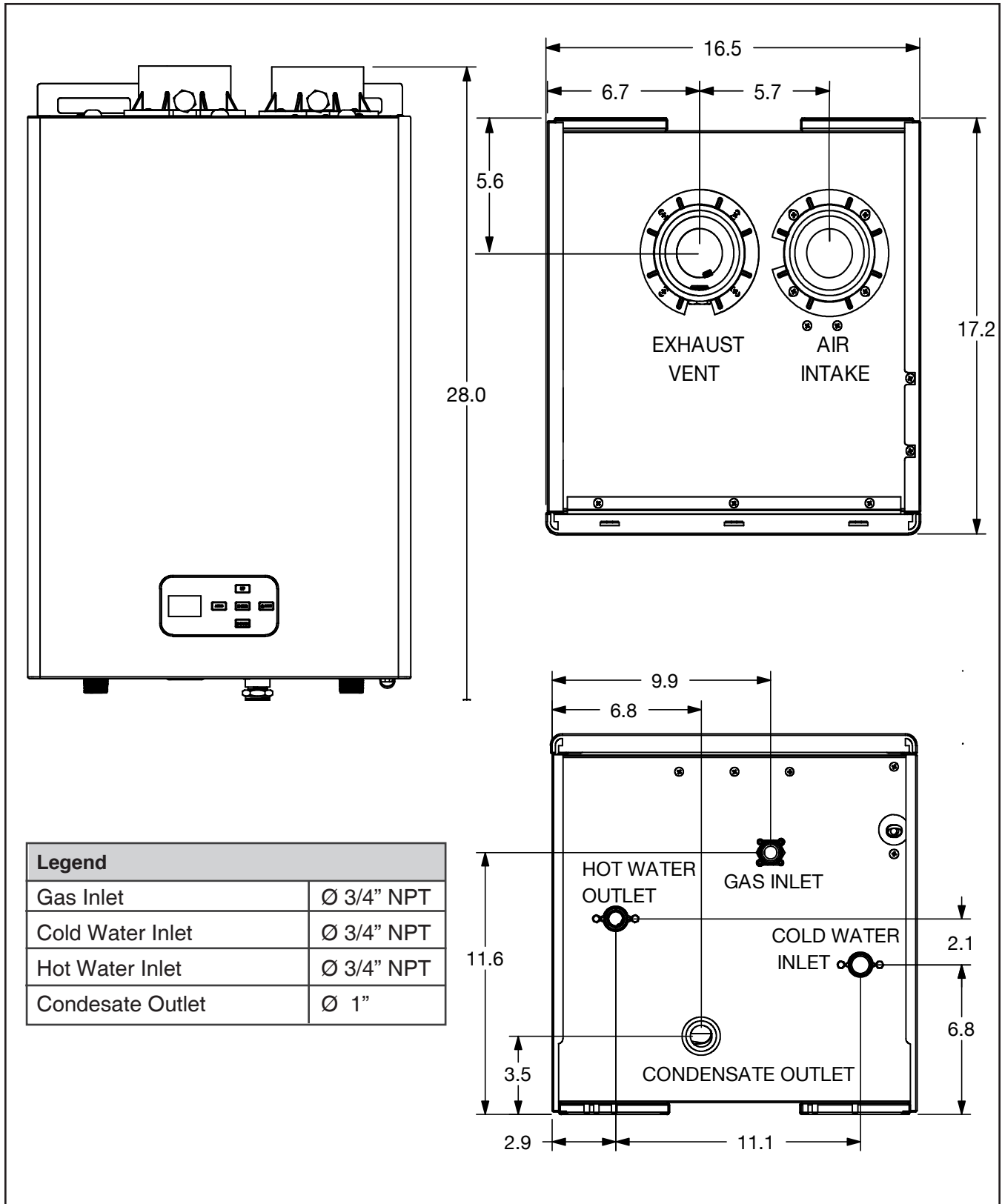

Figure 2.1 - Glow T180 Dimensions

**2.3 Unit Performance**

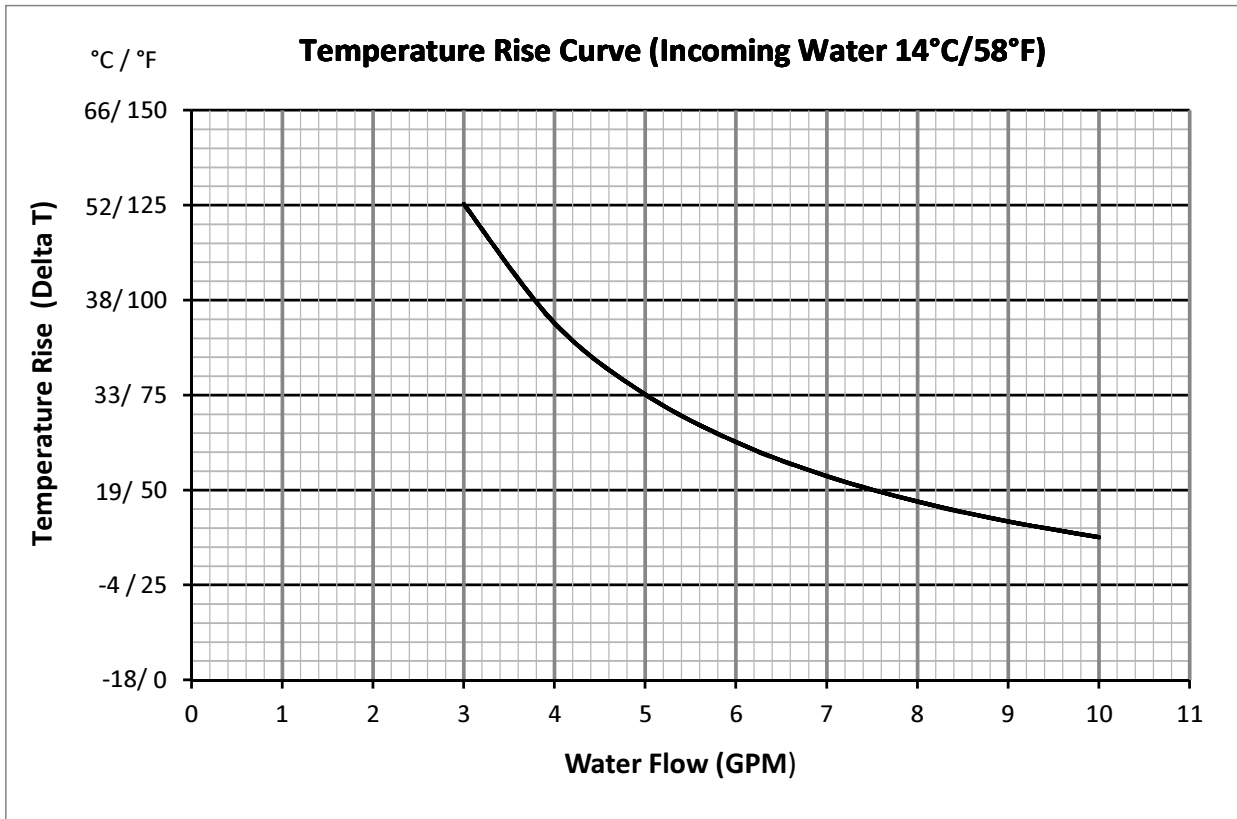

Table 2.2

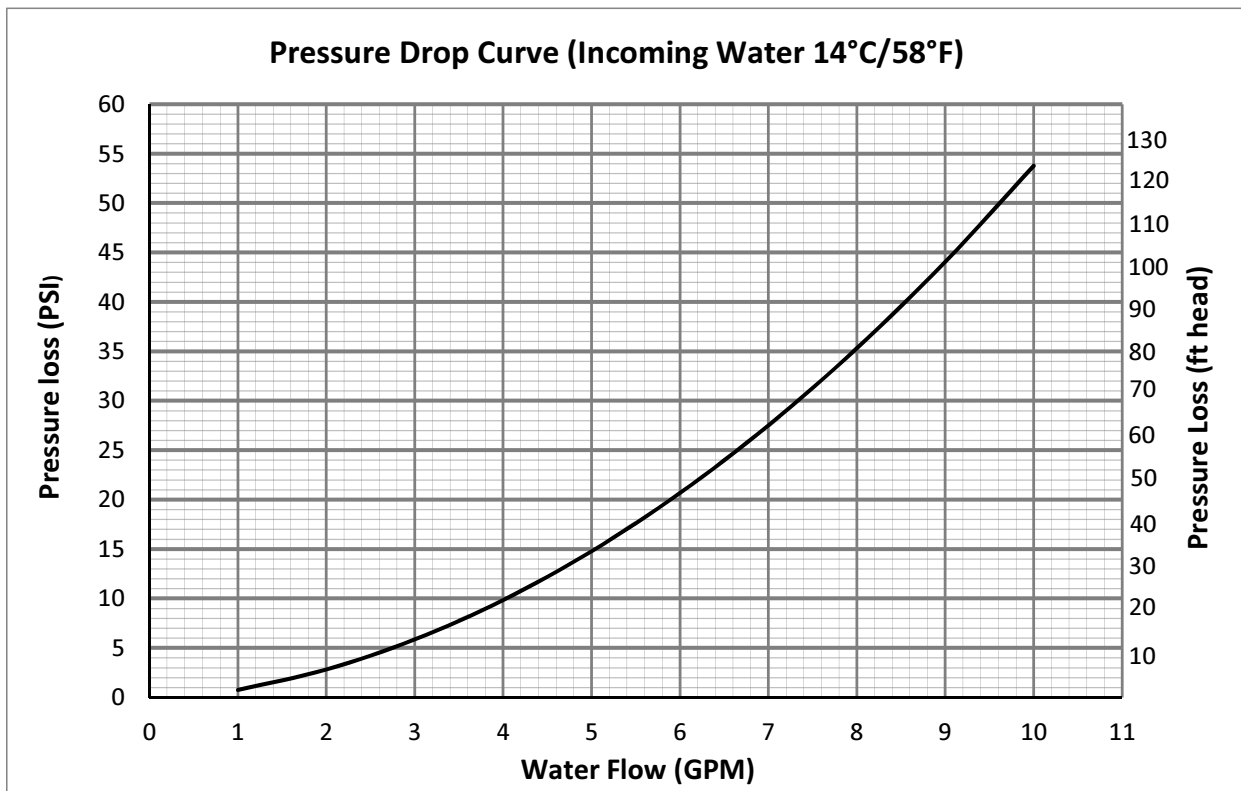

Table 2.3

2.4 Internal Parts Of The Water Heater

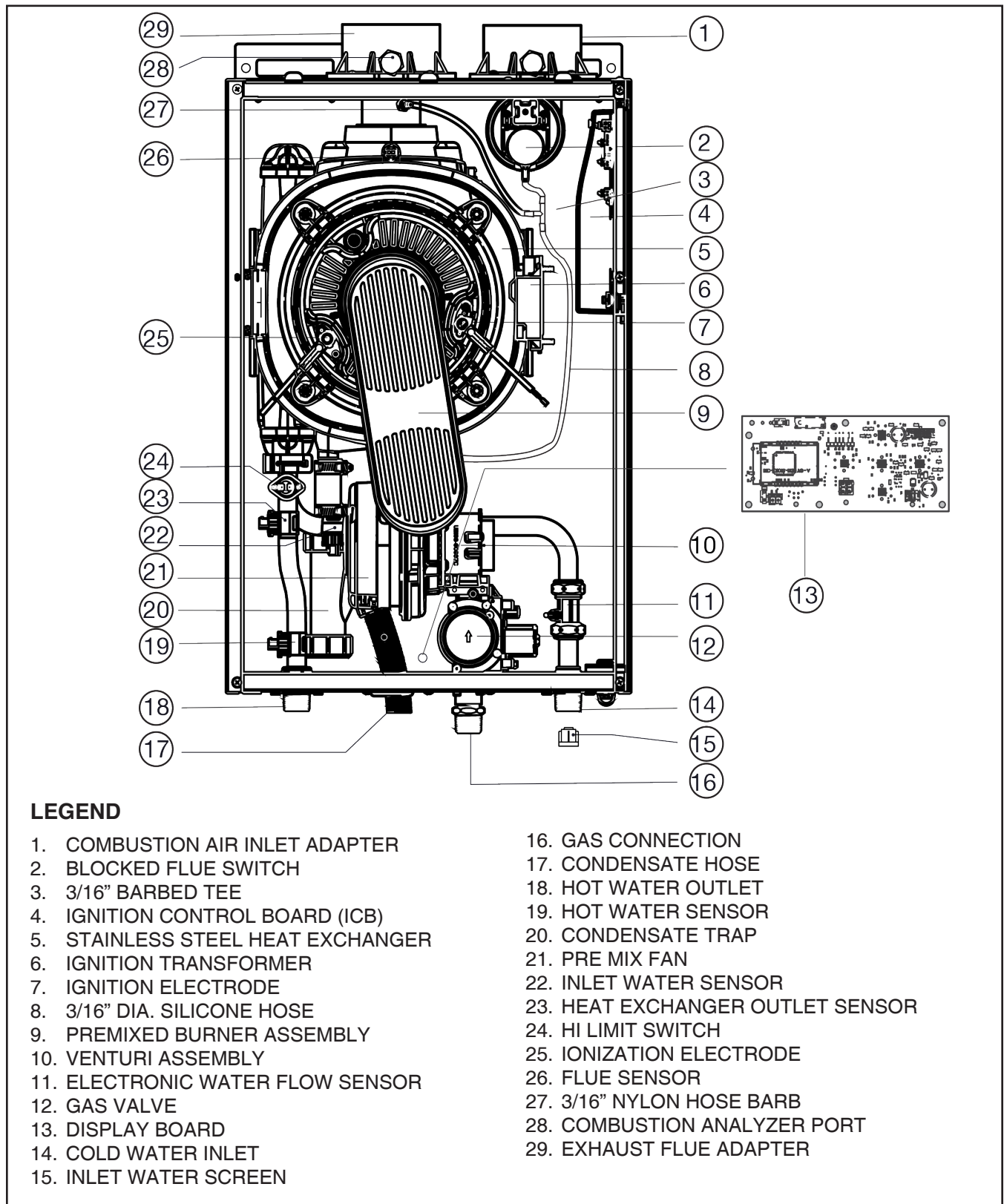

Figure 2.2- Water Heater internal parts

2.5 Display & Control Circuit Board

2.5.1 LCD Display

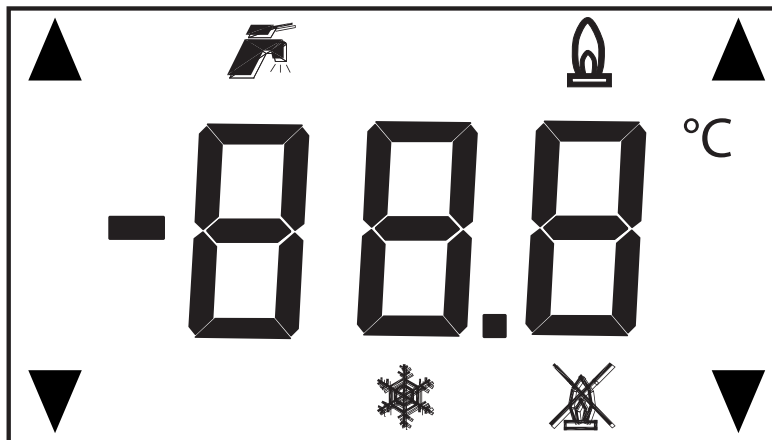

Figure 2.3- Water Heater display

2.5.2 Status Display Symbols

The table below describes the function of each symbol.





Status Symbol	Description
- - -	con – Connecting display with controller and start communication
i n i	ini – Initializing software
r d y	Standby
r d y and 	Preheat Domestic Hot Water
	Domestic Hot Water demand: the temperature display shows the actual flow temperature
	Indicates appliance burner is ON
	Alarm condition*: the alarm code is displayed (blinking) on the temp. display: A xx = Lockout error number E xx = Blocking error number
	Demand for frost protect is active, the temperature display shows the actual flow temperature
°C	Temperature in °Celsius, this value is displayed with a comma (e.g. 20,5 °C). If the value of the temp. is set to °F, the °C- icon will not show
▲▼	Located on top and bottom corner on the left side of the screen. This symbol is shown when scrolling through the User menu.
▲▼	Located on the top and bottom corner on the right side of the screen. Indicates when the up/down buttons should be used to set a parameter.

Table 2.4



## 2.5.3 Control Button Layout

5 different buttons are present on the LCD Display for operating the module. The buttons are positioned to the right of the display. (see fig. 2.4)

With these five buttons various layouts are possible. The display layout has the most frequent keys ([UP], [ENTER] and [DOWN]) placed vertically in the middle, which combines convenient navigation with a user friendly look, due to the silicone keypad.

The table below describes the button functions. (Table 2.5)

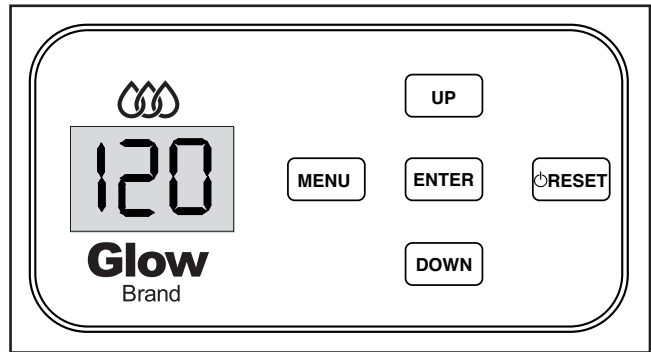

Figure 2.4- Control panel



Button	Function Description
 <b>RESET</b>	*Press and hold for 5 sec. to switch the display board ON or OFF. * Press to reset the appliance in case of a Lock-out error or Press to cancel an altered parameter
<b>MENU</b>	Press to enter the User menu or Press for 10 sec. to enter the Service menu
<b>ENTER</b>	Press to confirm when you have selected a parameter or Press to confirm an altered setting
<b>UP</b>	Scroll up or Increase the value (of a parameter)
<b>DOWN</b>	Scroll down or Lower the value (of a parameter)

Table 2.5

## 2.5.4 Direct Adjustments of DHW Set point via Main Display Screen

The DHW set point can be directly adjusted in the main screen only when the unit is in standby [  ]. In this case, the following icons are shown, including the set point temperature that is being altered.

Icons	Description
	DHW set point can be altered by using the [UP] and [Down] buttons

Table 2.6

## 2.5.5 Error Displayed on Screen

In case of a Warning, Error-/Alarm condition, the Blocking ('E'), Locking ('A') or Attenuations ('n') error will continually flash. The User menu is inaccessible and can only be reset by pressing [RESET]. See section 6- ('Lock Out & Warnings')

## 2.6 User Menu

Open the User view menu by pressing the [MENU] button once. This menu can be used to look at the values of a selection of parameters (read-only parameters) or to view the sensor temperatures. The scheme below shows how to operate the User menu in some simple steps:

1. Enter the User Menu	2. Scroll through Parameter List	3. Select parameter	4. Alter value of parameter	5. Confirm / cancel alteration
Press [MENU] button once	Scroll through the parameter list with the [UP] / [DOWN] buttons*  10 seconds of no action automatically return to the status screen.	Select a parameter to alter/read-out it's value by pressing [ENTER]**  10 seconds of no action automatically return to the status screen.	Alter a value of the parameter with the [UP] / [DOWN] buttons.  When the parameter is being altered, the value on the display will blink.	Confirm (save) with [ENTER] or Cancel with [RESET]  After saving/cancelling you automatically return to the installer selection (1).

\* If these buttons are no longer operated for 2 sec. the parameter no. and the current value displayed will show with intervals of 2 sec.

\*\* In case of a non-adjustable parameter, the current value will be displayed continuously.

Table 2.7

The following table describes of the parameters in the User menu, which are all read-only.

Parameter	Description	Value
100	Heat Exchanger outlet sensor	°C or °F
101	Outlet water sensor	°C or °F
102	Flue gas temperature sensor	°C or °F
103	Inlet water sensor	°C or °F
108	Ionization current	µA
111	DHW pump status	Does Not Apply
140	Actual fan speed	X 10 RPM *
141	Ignition fan speed	X 10 RPM *
142	Minimum fan speed	X 10 RPM *
143	Maximum fan speed	X 10 RPM *
151	Last Lockout number	#
152	Last Blocking error	#
153	Number of flame failures	#
154	Number of successful ignitions	#
155	Number of failed ignitions	#
157	Total hours of operation for the DHW	X 10 Hrs**
158	Total days of operation of the burner	Days
159	Interval between lockout errors	Minutes
160	Interval between blocking errors	Minutes

\* The value of these parameters are given in RPM. Because the display can only show 3 digits, the number on the screen has to be multiplied times 10. For example, when the display shows the number 20, it means that RPM is 20x10, i.e. RPM is 200.

\*\* The value of this parameter is the number of hours times 10. For example, if the number on the display says 50, it means 50x10, which is 500 hours.

Table 2.8

## 2.7 Service Menu

The scheme below schematically shows how to operate the Service Menu in some simple steps:

1. Enter the Service Menu	2. Scroll through Parameter List	3. Select parameter	4. Alter value of parameter	5. Confirm / cancel alteration
Hold [MENU] for 5 seconds. Display will alternately flash parameter 207 and its value set point.	Scroll through the parameter list with the [UP] / [DOWN] buttons*  10 seconds of no action automatically return to the status screen.	Select a parameter to alter/read-out it's value by pressing [ENTER]**  10 seconds of no action automatically return to the status screen.	Alter a value of the parameter with the [UP] / [DOWN] buttons.  When the parameter is being altered, the value on the display will blink.	Confirm (save) with [ENTER] or Cancel with [RESET]  After saving/cancelling you automatically return to the installer selection (1).

\* If these buttons are no longer operated for 2 sec. the parameter no. and the current value displayed will show with intervals of 2 sec.

\*\* In case of a non-adjustable parameter, the current value will be displayed continuously.

Table 2.9

The following table shows the available parameters in the Service menu.

Parameter no.	Description	Value
207	Set point (Default 120°F/49°C)	Min.102°F - Max 145°F (Min. 39°C - Max. 63°C).
208	Rest Function	ON (default), OFF
210	System test power	OFF: Don't apply rEg: Don't apply  FAn: Fan rotates at maximum RPM  (Flow water through heater for following tests) Lou: Burner fires at minimum power Ign: Burner fires at Ignition power Hig: Burner fires at maximum power
214	Display test (when [UP] button is pushed all icons and LEDs will light-on. Press [RESET] to go back to the settings menu. *	
260	Don't Apply	
261	Don't Apply	
280	Service Reminder. Status jumps back.	ON, OFF, rSt (Reset)
281	Service Reminder setting	Days (in steps of 5)

Table 2.10

## 2.8 Installer Section

The Installer section ensures that one control can control several different devices. The scheme below schematically shows how to operate the installer Section in some simple steps:

1. Enter the Installer Selection	2. Scroll through Parameter List	3. Select parameter	4. Alter value of parameter	5. Confirm / cancel alteration
<p>Power <b>OFF</b> unit Remove power cord from receptacle. Simultaneously press and hold <b>[MENU]</b> &amp; <b>[ENTER]</b> while plugging in the power cord. Continue to hold <b>[MENU]</b> &amp; <b>[ENTER]</b> until the display flashes <b>ini</b> &amp; <b>300</b> alternately for 10 seconds. It will rest at <b>302</b>.</p>	<p>Scroll through the parameter list with the <b>[UP]</b> / <b>[DOWN]</b> buttons*</p> <p>10 seconds of no action automatically return to the status screen.</p>	<p>Select a parameter to alter/read-out it's value by pressing <b>[ENTER]</b>* **</p> <p>10 seconds of no action automatically return to the status screen.</p>	<p>Alter a value of the parameter with the <b>[UP]</b> / <b>[DOWN]</b> buttons.</p> <p>When the parameter is being altered, the value on the display will blink.</p>	<p>Confirm (save) with <b>[ENTER]</b> or Cancel with <b>[RESET]</b></p> <p>After saving/cancelling you automatically return to the installer selection (1).</p>

\* If these buttons are no longer operated for 2 sec. the parameter no. and the current value displayed will show with intervals of 2 sec.

\*\* In case of a non-adjustable parameter, the current value will be displayed continuously.

Table 2.11

The following table shows the available parameters in the Service menu.

Parameter no.	Description	Value
302	Appliance selection model	1
303	Display units	°C/ °F (Stored in the internal memory)
312	DHW mode	<p><b>Only select the following mode:</b> 08: Tankless water heater</p> <p><b>Don't apply the following modes:</b> 00: N/A 01: N/A 02: N/A 03: N/A 05: N/A 06: N/A 07: N/A</p>
314	DHW mode preheat	dIS = Disabled (no preheat) EnA = Enabled (preheat) default
317	DHW setpoint Max	160°F(70 °C) (Stored in the internal memory, default value 70°C)
318	DHW setpoint Min	102°F(39°C) (Stored in the internal memory, default value 39°C)
319	DHW mode preheat	00: Preheat Off mode 01: Anti freezing mode (Default) 02: Eco mode 03: Comfort mode
324	Temp. Lock Condition	EnA (Enabled) default, dIS (Disabled)

Table 2.12

**ECO Mode:** When the unit is set in **ECO Mode**, the water within the heat exchanger is maintained at 30°C/86°F. This mode allows the unit to fire up momentarily in order to maintain a consistent temperature within the heat exchanger.

**Comfort Mode:** When the unit is set to **Comfort Mode**, the water within the heat exchanger is maintained at 20°C/35°F less than the programmed DHW set point. This mode offers the homeowner the opportunity of having 1 gallon of water stored within the heat exchanger at a higher temperature than incoming water from the main. This operation benefits the homeowner by reducing the “Cold Water Sandwich” effect. See Table 2.13 for desired storage temperature.

 **Warning: IMPORTANT** - Set point temperature cannot exceed 145°F/63°C in **ECO** or **Comfort** mode when connected to a space heating source that utilizes an automatic DHW flush cycle. Cycle duration should not exceed 5 minutes every 24 hours.

**DHW Lock Condition:** Can be used to enable/disable a ‘Temperature Lock Condition’ during tapping of DHW; this means that you cannot adjust the set point during tapping. If it is enabled and the user presses UP/ DOWN the display will show ‘Loc’ to inform the user, this function is locked.

DHW SET POINT	H.E. WATER TEMP
49°C/120°F	29°C/84°F * up to 52°C/125°F
55°C/130°F	35°C/95°F * up to 57°C/135°F
60°C/140°F	40°C/104°F * up to 63°C/145°F
63°C/145°F	43°C/110°F * up to 63°C/145°F

\* approximate values

Table 2.13

 **DHW Set point cannot be set higher than 145°F/63°C for ECO and Comfort modes**

 **A thermostatic mixing valve must be added to this system to prevent scalding and as per local codes and authorities.**

Table - Risks of Scalds

Temperature Setting	Time to Produce 2nd, 3rd Degree Burns on Adult Skin
Over 170°F/77°C	Nearly instantaneous
160°F/71°C	About 1/2 second
150°F/66°C	About 1-1/2 seconds
140°F/60°C	Less than 5 seconds
130°F/54°C	About 30 seconds
120°F/49°C or less	More than 5 minutes

To protect against injury, you must install a tempering valve in the water system. This valve will reduce point of discharge temperature by mixing cold and hot water in branch supply lines. Such valves are available from the local plumbing supplier.

## 3. Installation (Authorized Personnel)

### 3.1 Reference Standard

Install in accordance with local building and electrical codes.

This appliance meets the requirements of:

American National Standard/CSA Standard for Gas Water Heaters Volume III, Storage Water Heaters with input Ratings above 75,000 Btu per Hour, Circulating and Instantaneous Conforms to ANSI STD Z21.10.3, certified to CSA STD 4.3-2015.

Failure to install a gas appliance correctly and in accordance with the above norms could lead to prosecution. It is in the interest of the installer and safety that the codes are complied with. The manufacturer's instructions form an integral part of the installation and should be left with the appliance but do not over ride in anyway statutory obligations.

#### 3.1.1 Installation Requirements

Please refer to local and national standards in force with the country of destination of the product.

#### 3.1.2 High Altitude Operation

The **Glow T180** unit is designed to operate at its maximum listed capacity in installations located at 0-2,000 ft above sea level. Since the density of air decreases as elevation increases, maximum specified capacity should be de-rated for elevations above 2,000 ft (610m) by 10%.

Any installation over 4,000 ft, the unit should be de-rated by 20%. Consult local authorities for de-rating for altitudes above 4,500 ft (1,372m).

### WARNING

Combustion – At elevation above 2,000 ft, the combustion of the **Glow T180** unit must be checked with a calibrated combustion analyzer to ensure safe and reliable operation. It is the installer's responsibility to check and adjust the combustion accordingly. Failure to follow these instructions may result in property damage, serious injury or death.

### 3.2 Unpacking

- Δ The materials (cardboard) used for packing the appliance are fully recyclable.
- Δ It is recommended that the packing material is

only removed prior to installing the water heater. The manufacturer will not be held responsible for damage caused by incorrect storage of the product.

- Δ Packing materials (plastic bags, polystyrene, etc.) must not be left within reach of children, in that these items represent a potential hazard.

- A. Place the packed appliance on the floor (see fig. 3.1) making sure that the unit is in its upright position. Open out the four flaps of the box.
- B. Rotate the packed appliance 180° so that the top is upside down while manually supporting it from underneath.
- C. Lift the box and remove the foam packaging. Lift the water heater by grasping the rear part and proceed with the installation.

### STORAGE & HANDLING

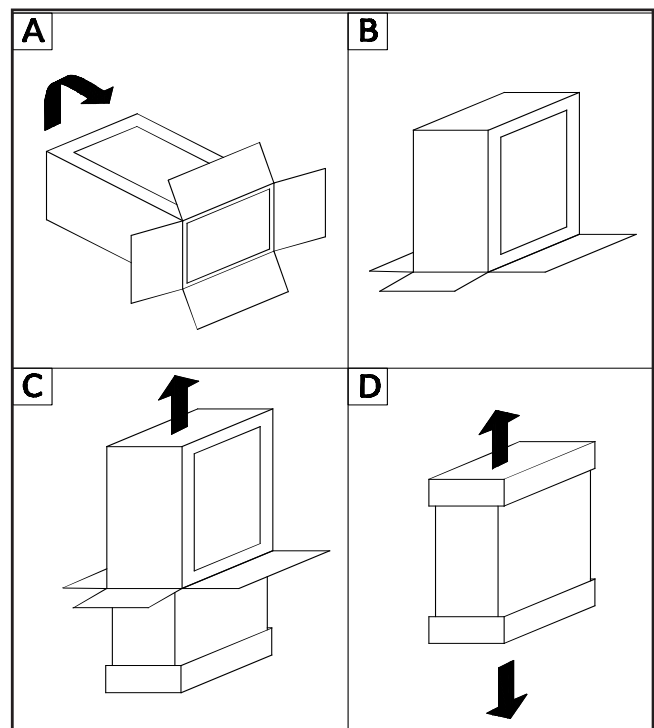



Figure 3.1 - Unpacking the water heater

Please note that prior to installation the **Glow T180** water heaters should be stored in the horizontal position with no more than three water heaters to a stack; Ensure that the water heaters are stored in dry conditions and the temperature does not drop below 0°C/32°F when in storage.

**3.3 Installing The Water Heater**

 The appliance must be securely installed exclusively on a vertical solid wall capable of supporting its weight. The water heater should be installed within the building unless otherwise protected by a suitable conditioned enclosure, i.e. garage.

- Δ If the water heater is installed in an unheated area it is recommended to leave the ON/OFF switch always in the ON position in order to activate the frost protection function
- Δ In order to allow access to the interior of the water heater for maintenance purposes, it is important that the minimum distances indicated are respected. (Clearance Diagram)

When selecting the location for the placement of the **Glow T180** unit, make certain the wall can adequately support the weight of the unit. Additional support such as a piece of 3/4" plywood 24" by 36" may be required To install the water heater, proceed as follows (see Clearance Diagram):

1. Use a level to mark a horizontal line on the wall where the water heater is to be installed.
2. Position the support bracket (see fig. 3.3) which is supplied with the **Glow T180** water heater above the line drawn with the level, respecting the distances indicated. Mark the center positions of the two wall-plugs or anchors. Finally, mark the positions of the water lines and gas pipe.
3. Once the bracket is firmly secured to the wall. The **Glow T180** unit can now be mounted on the support bracket. Connect the domestic hot and cold water pipes and the gas supply pipe. You have the option of using field supplied NPT service valve kit (preferred method) or field supplied NPT to sweat adapter along with the relief valve and bronze tee supplied with all units.

**Clearance to Combustibles:**

Minimum clearance from combustible or non combustible construction. (see fig. 3.2)

- Front – 0 inches
- Sides – 0 inches
- Rear – 0 inches
- Top – 0 inches from front panel

Service clearance - 24" front of unit

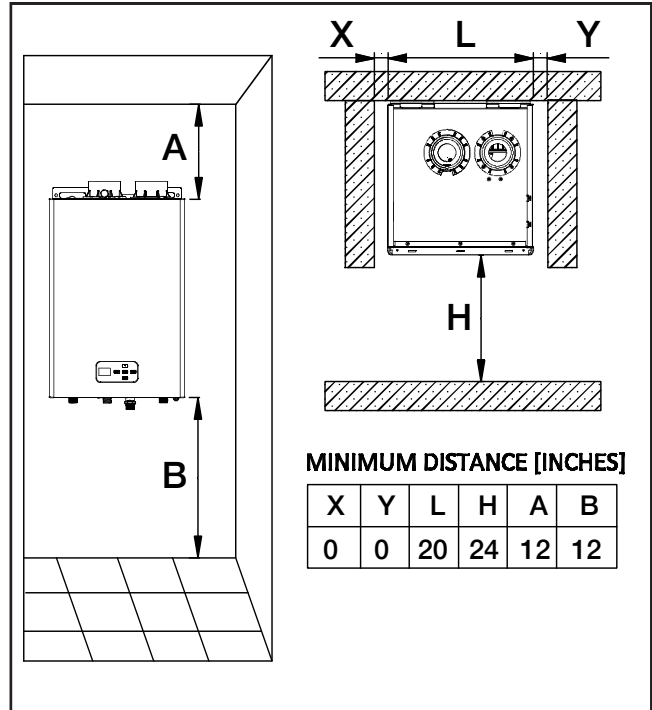

Figure 3.2 - Clearance Diagram

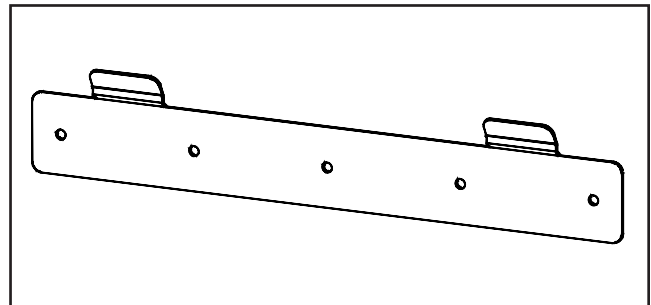

Figure 3.3 - Support Bracket

**3.4 Domestic Hot Water**

 **Warning/ Hard Water**

- Δ If this water heater is installed in an application where the supply water is hard, it must be treated with a water softener or filtration device which removes the hardness, or by using sequestering agents that reduce the amount of scale deposits.
- Δ Damage to the water heater as a result of water in excess of 14.5 gpg (250mg/L) of hardness is not covered by **Glow Brand** Limited warranty. If there a problem with the water quality, contact your local water conditioning company for equipment to condition the water supply to this appliance.

The water supply pressure at the inlet to the water heater must be between 30 psi (2.15 bar) and 85 psi (6 bar).

**In areas with higher water inlet pressure a pressure reducing valve must be installed before the water heater.**

Cleaning the heat exchanger coil annually is recommended. More frequent heat exchanger coil cleaning is required based on the hardness of the main water supply and the presence of residual solids or impurities which are often present in the case of a new installation. If the characteristics of the water supply are such that require it to be treated, then an appropriate treatment devices must be installed.

**3.4.1 Water Supply Quality**

**⚠ CAUTION: This water heater MUST ONLY be used with the following water supply conditions to prevent product damage and operation failure.**

- △ Clean, potable water free of corrosive chemicals, sand, dirt or other contaminants.
- △ Inlet water temperatures above 0°C (32°F), but not exceeding 49°C (120°F)
- △ DO NOT reverse the HOT and COLD water connections
- △ DO NOT connect this water heater to water lines previously used for space heating. All water piping and components shall be suitable for potable water.
- △ With recommended water quality (see table 3.1)

**Water Quality Chart**

pH	6.5-8.5
TDS (Total Dissolved Solids)	Up to 500 mg/L
Free Carbon Dioxide (CO2)	Up to 15 mg/L
Total Hardness	Up to 150 mg/L
Aluminum	Up to 0.2 mg/L
Chlorides	Up to 200 mg/L
Copper	Up to 1.0 mg/L
Iron	Up to 0.3 mg/L
Manganese	Up to 0.05 mg/L
Zinc	Up to 1.0 mg/L

Table 3.1

**3.4.2 Thermal Expansion Device**

If this water heater is installed in a closed water supply system, such as one having a back-flow preventer in the cold water supply, provisions must be made to control thermal expansion. DO NOT operate this water heater in a closed system without provisions for controlling thermal expansion.

**3.4.3 Inlet Screen**

This unit comes complete with a water inlet screen which is factory installed in the cold water inlet fitting. Do not operate this unit without the inlet screen in place. Doing so can and will cause serious damage to the unit and will void the warranty. Should there be reduced water flow than what is expected, the water inlet screen may be dirty and needs to be removed, cleaned or replaced. (see fig. 3.4)

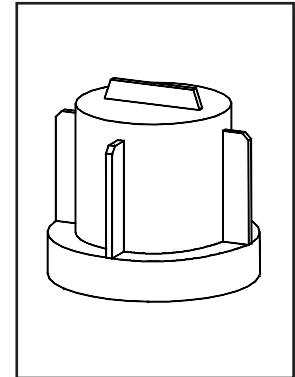

Figure 3.4 Inlet Screen

**3.4.4 Water Supply Conditions**

**⚠ CAUTION: IMPORTANT** – Do not apply heat to the HOT and COLD water connections. If connections are used, solder tubing to the adapter before fitting the adapter to the water connection on the water heater. Any heat applied to the water supply fittings will permanently damage the internal components of the water the water.

Plumbing should be carried out by a qualified plumbing professional in accordance with local codes. Only use approved plumbing materials. To conserve energy and to prevent freezing, insulate both HOT and COLD water supply lines. Do not insulate the drain line or pressure relief valve.

**⚠ IMPORTANT** – Anti scald mixing valve must be installed and as per local codes and authorities.



### 3.4.5 Condensate Drain

- △ The **Glow T180** water heater is a high efficient gas appliance that creates condensation when it operates. A condensate trap and flexible drain pipe come with each water heater and must be installed below the cabinet.



The condensate trap must be primed before operation to prevent exhaust gases from entering the building. (see Section 4.4)

- △ Follow your local code with regards to the disposal of condensation.
- △ Here are several options for disposal of condensate:
  - From tankless water heater direct to drain
  - From tankless water heater to neutralizer to drain.
  - From tankless water heater to laundry tub (bottom of water heater must be above the height of the laundry tub; must have a negative slope to properly drain).
  - From tankless water heater to condensate pump to laundry tub (for long distances between water heater and laundry tub or when bottom of the water heater is installed below height of the laundry tub).
- △ Failure to install the condensate discharge properly will affect the reliability of the water heater.
- △ All units installed with vertical exhaust must have a horizontal condensate tee piped to the drain and must be ULC S636 approved.
- △ Failure to properly connect the condensate drain will cause combustion gases to enter the room, possibly causing serious injury to occupants or death.
- △ Note: Check with your municipality, local codes, or local gas company to determine if disposal of combustion condensate is permitted. In the State of Massachusetts the condensate must be neutralized prior to entering a drain.
- △ Use only PVC, Vinyl or CPVC pipe for the condensate drain line. Metal pipe is not suitable for condensate discharge.
- △ The condensate drain line should be a minimum of 1/2" diameter that connects to the 3/4" supplied hose and must be supported to prevent sagging. Manufacturer will supply a 3/4" to 1/2" reducer for connection.

- △ Keep the length of the condensate drain as short as possible. Long runs or applications where the nearest drain is above the water heater will require the use of a condensate pump. Size the pump to allow for a maximum condensate discharge of 2 gpm from the water heater. The end drain pipe must not be submerged in water or blocked in any way.
- △ Ensure the condensate is flowing freely from the drain pipe after the system has been installed. Condensate will begin flowing out of the water heater within 2 minutes after operation has started.
- △ Do not run condensate lines outside and take measures to prevent the condensate drain lines from freezing (insulation, heat tape, electric heaters, etc.).
- △ Be sure to clean the condensate trap at least once per year to prevent any problems, and after cleaning be sure to check for any leaks of condensed water or flue gas. (see Section 4.4)

### 3.4.6 Space Heating

- △ Suitable for combination water (Potable) heating and space heating (maximum set point of 63°C/145°F) and not suitable for space heating application only.
- △ Piping and components connected to the water heater for the space heating application shall be suitable for use with potable water.
- △ Toxic chemicals, such as used for water heater treatment, shall not be introduced into the potable water.
- △ A water heater which will be used to supply potable water shall not be connected to any heating system of component(s) previously used with non-potable water heating appliance.
- △ When the system requires water for the space heating at temperatures higher than required for other uses, a means such as a mixing valve shall be installed to temper the water for those uses in order to reduce scald hazard potential.
- △ The water heater can be used for potable hot water heating and space heating (maximum set point of 63°C/145°F) applications. Note: the illustrations in section 3.4.7 are conceptual designs only. There are many design variations of the equipment presented. Designers must add all necessary safety and auxiliary equipment to conform to Code requirement and proper design practice. For more details, contact the manufacturer or distributor.

3.4.7 Schematics Of Piping Installation

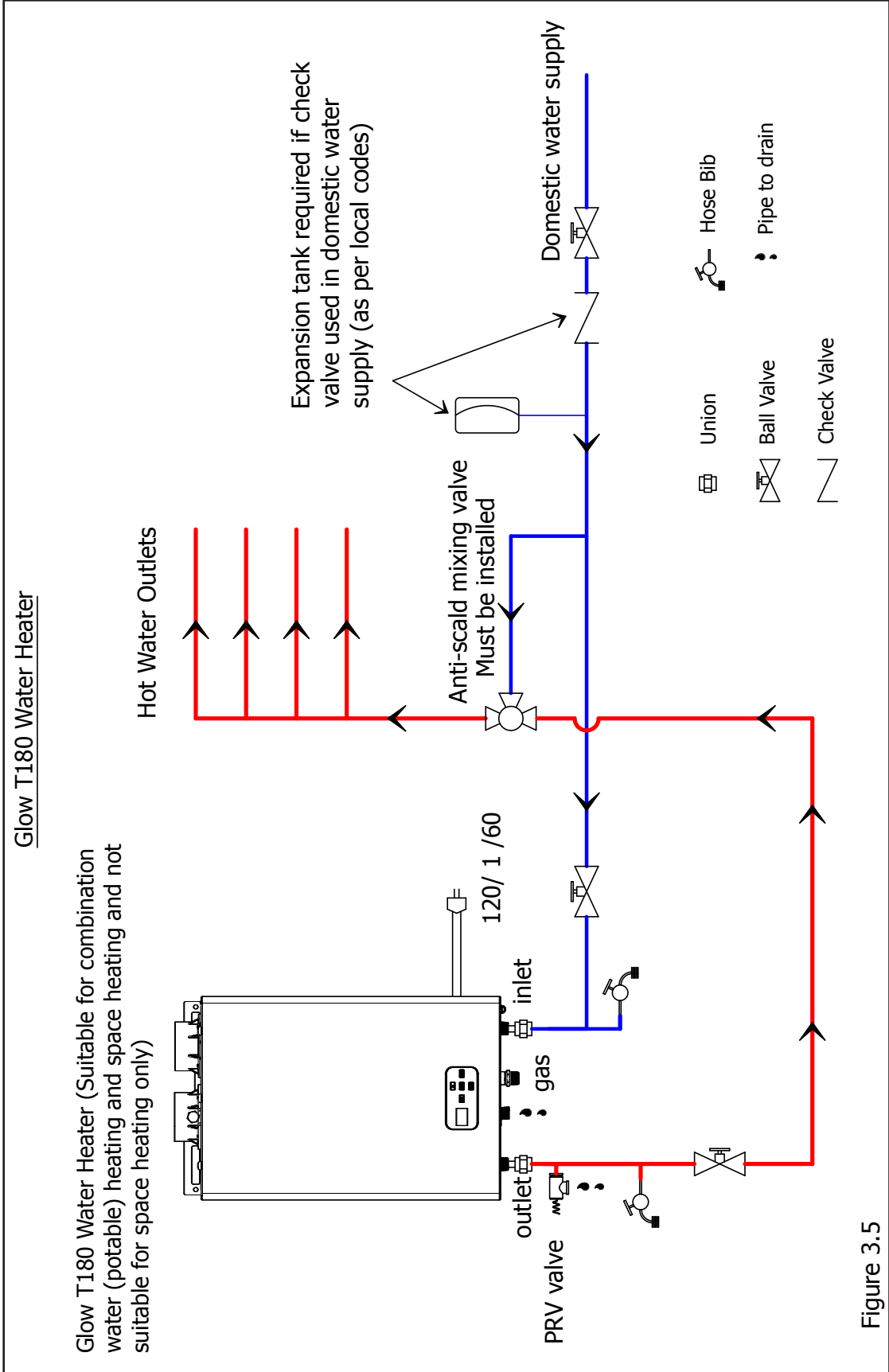

Figure 3.5

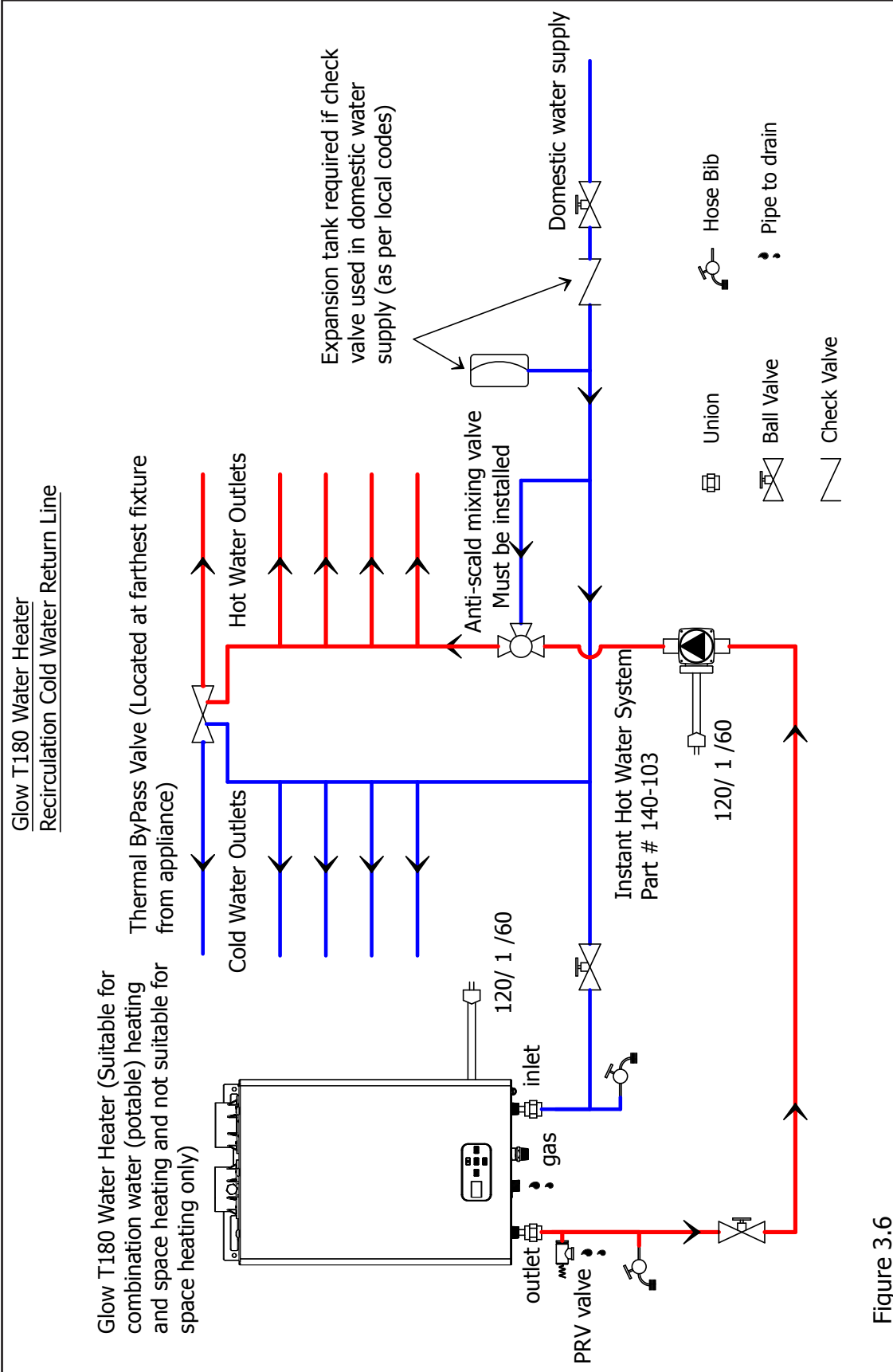

Figure 3.6

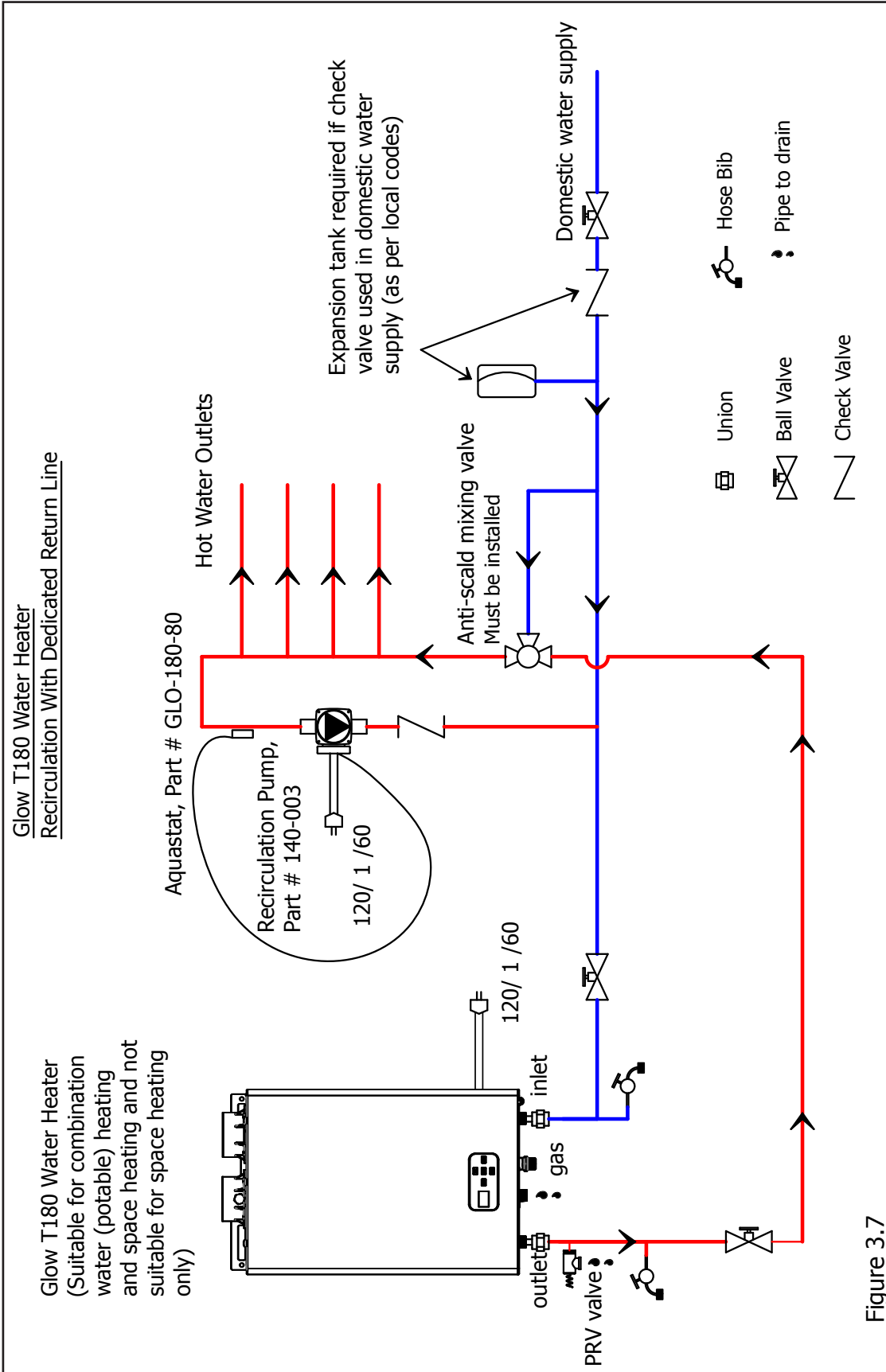

Figure 3.7

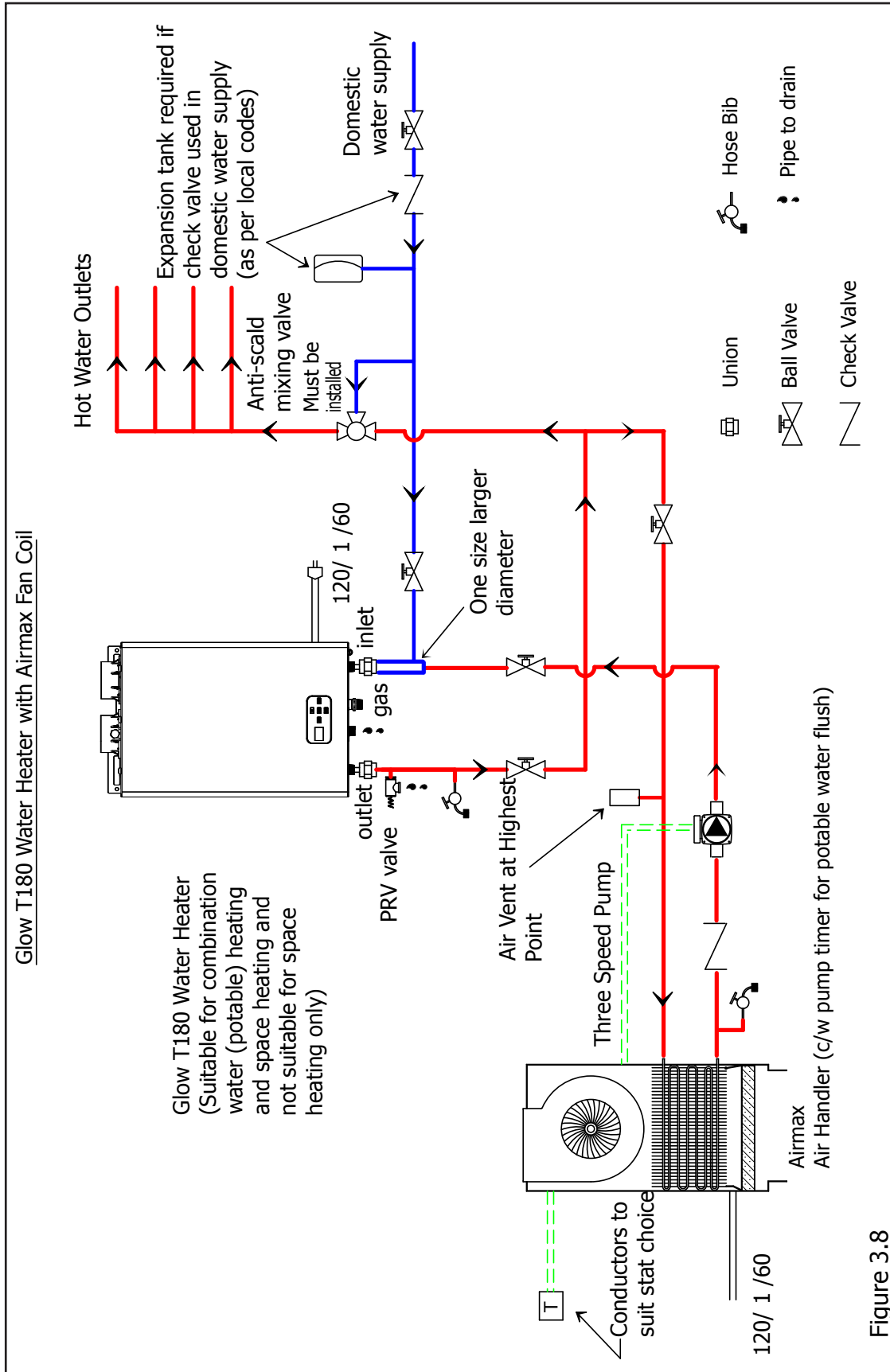

Figure 3.8

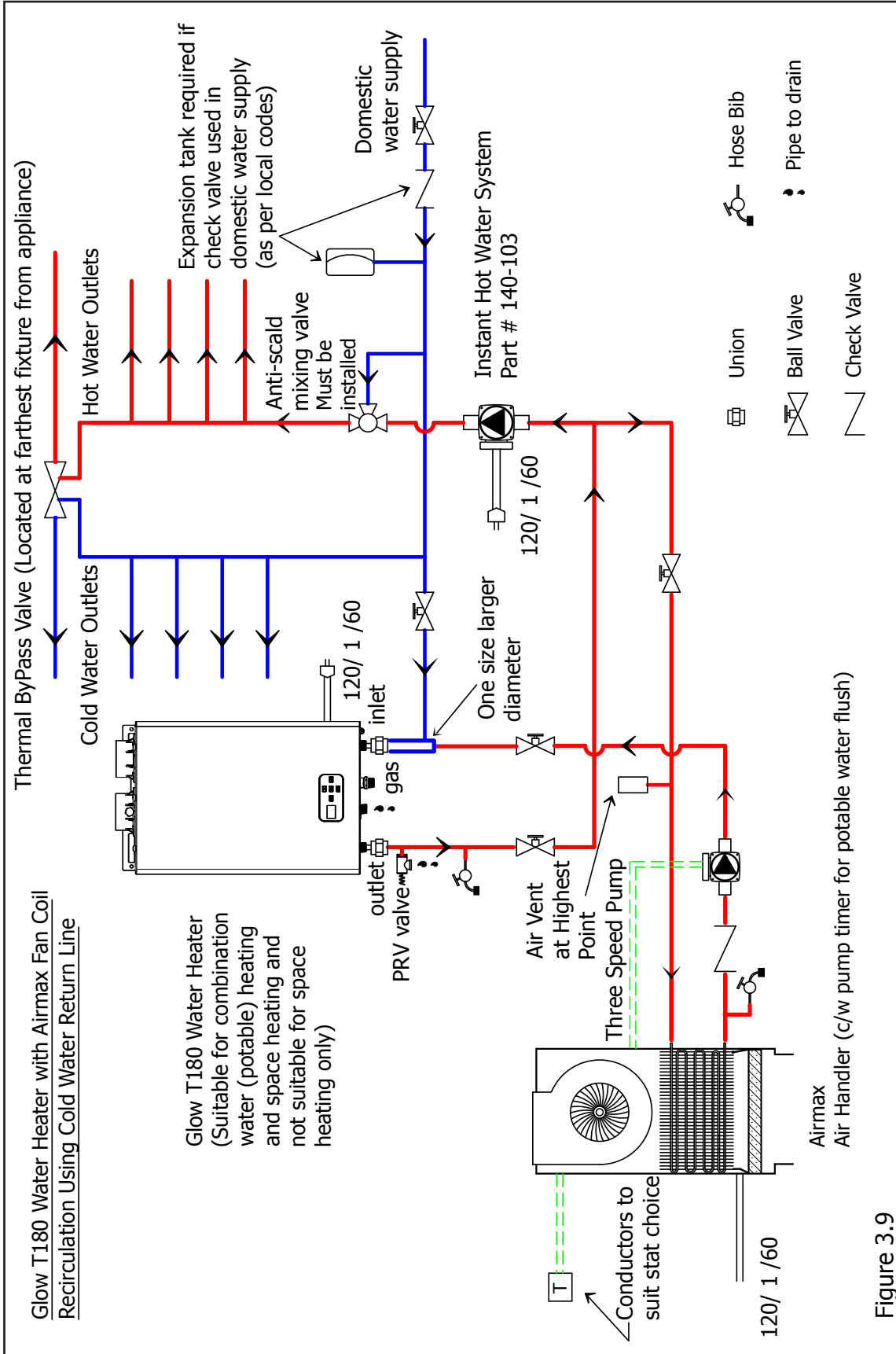

Figure 3.9

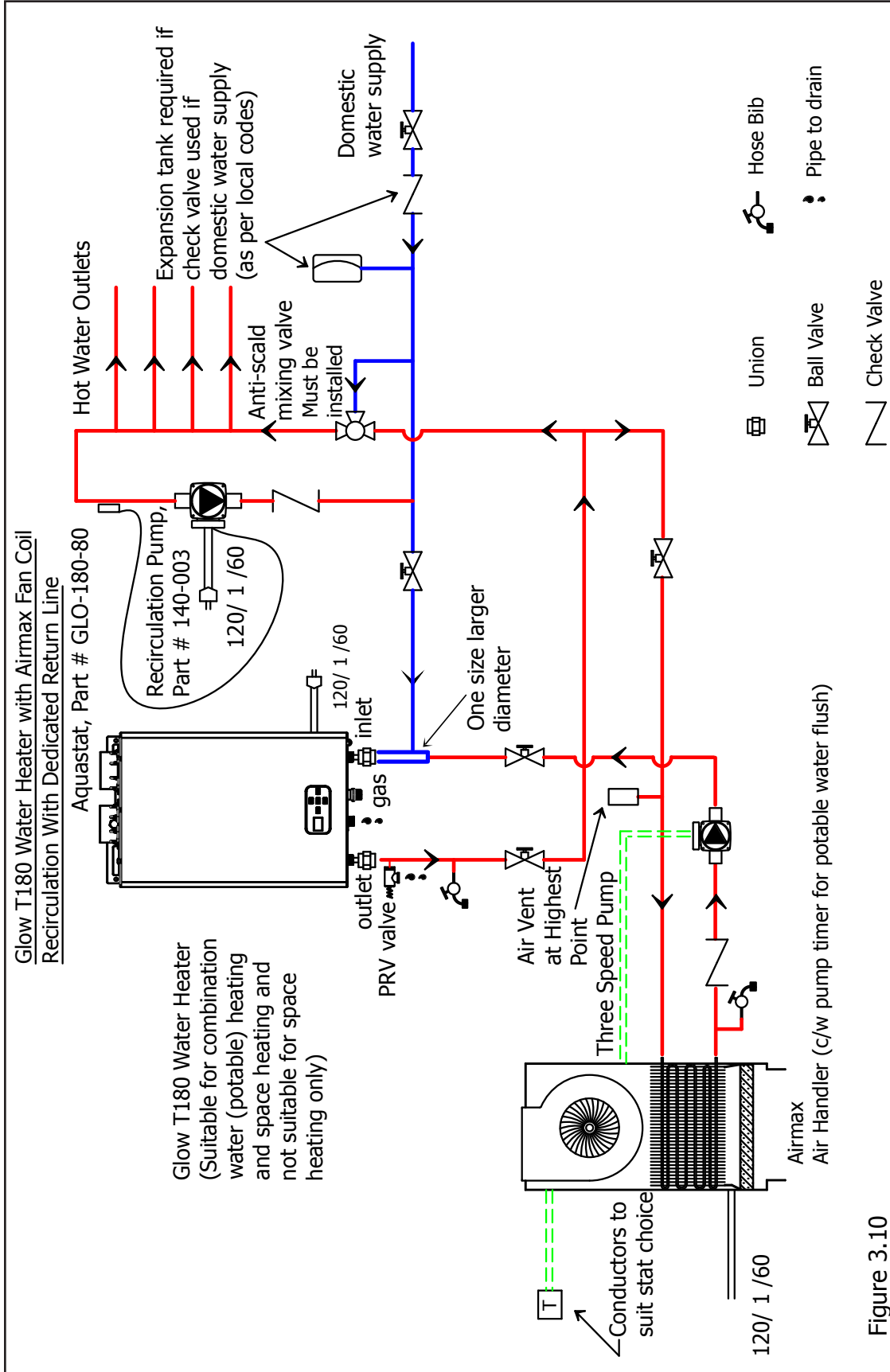

Figure 3.10

### 3.5 Recirculation Pump

Hot water Re-Circulation is allowed on the **Glow T180** tankless water heater, provided a factory verified method is utilized. The appliance minimum flow for operation is 0.6 gpm (2.27 lpm).

#### Dedicated Hot Water Return Line

##### Option 1

Pump part # 140-003  
Aquastat part # GLO-180-80  
Connection Kit part# 96806141 (1/2") or,  
Connection Kit part# 96806143 (3/4")

See **Figure 3.7 & 3.10** for system configuration. This system is comprised of a circulating pump, connection kit with integral check valve, and aquastat. This aquastat must be secured to the dedicated return line as indicated. The pump will operate once the supply line temperature is below 105 °F. Once the supply line reaches 115°F the pump will shut off. It is not recommended to operate the pump constantly without the aquastat connected. Doing so will alter the appliance warranty period (as per **Glow Brand** standard published warranty). The target system flow for this option is 1.0 gpm and the allowable external pressure drop is 19 ft.wg. Specific job head calculation is the responsibility of the designer or installer. The maximum water temperature allowed is 230 °F.  
(See **Figure 8.7** on page 74)

#### Recirculation Pump Information

Demand initiated systems are strongly recommended, however, due to their complexity please contact **Glow Brand** for further information.

#### Cold Water Return Line

##### Option 2

Pump part # 140-103  
Connection kit part # 529913 (1/2") or,  
Connection kit part # 529911 (3/4")  
Bypass Valve part # GLO-103-01  
Flex Hose kit part # GLO -103-03 (3/8"x1/2") 2 hoses per kit

See **Figure 3.6 & 3.9** for system configuration. The system is comprised of a pump with integral time clock and cord set, thermal bypass valve, and four flex connection hoses. It is not recommended to operate the pump constantly without the time clock functioning. Run time should not exceed 8 hrs per 24 hr cycle. Doing so will alter the appliance warranty period (as per **Glow Brand** standard published warranty). The target system flow for this option is 1 gpm and the allowable external pressure drop is 12 ft.wg. Specific job head calculation is the responsibility of the designer or installer. The maximum water temperature allowed is 230 °F.  
(See **Figure 8.7** on page 74)



## 3.6 Water Connections

**!** In order to safeguard the heat exchanger, especially in case of water heater replacement, it is recommended that the system is hot-flushed to remove any impurities (especially oil and grease) from the pipes.

**!** Make sure the water pipes are not used to ground the electrical system. The pipes are unsuitable for this purpose.

**!** A sediment inlet water screen is supplied and already installed in every unit. Do not allow water to flow into the unit unless the dirt inlet water screen is in place. Serious irreparable damage can occur and void the warranty.

### 3.6.1 Pressure Relief Valve And Tee

#### Operation and Maintenance Instructions

Should the installer choose not to use the isolation valve kit, then a pressure relief valve and tee must be used. Either kit is available from the manufacturer.

#### Installation

The Pressure Relief Valve and Tee must be installed in place of the optional Tankless Water Heater Isolation Valve Kits in accordance with local code requirements. In the event that these instructions conflict with code requirements, the code shall take precedence. (Figure 3.14 & 3.15)

- Δ Install the forged brass tee onto the hot water outlet of the water heater. The pressure relief valve is to be fitted into the branch port of the tee. Be sure to use Teflon tape or approved thread sealer when fitting the assembly together. The outlet connection of the pressure relief valve must face down.
- Δ The appropriate 3/4" adapters can be fitted to the HOT and COLD water lines.
- Δ A pressure relief valve, complying with the Standard for Relief Valves and Automatic Gas Shut-Off Devices for Hot Water Supply Systems, ANSI Z21.22/CSA 4.4, must be installed at the HOT water outlet connection of the water heater during installation. Local codes shall govern the installation of any relief valve.

**!** **IMPORTANT – Anti scald mixing valve must be installed and as per local codes and authorities.**

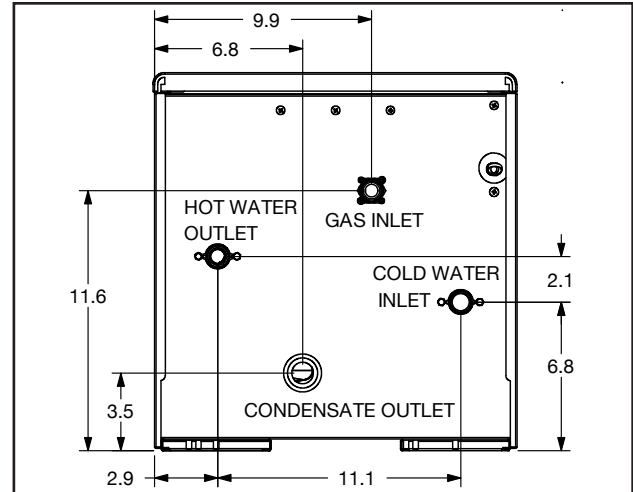

Figure 3.13 - Water Heater Connections (inches)

Connection	Size
Cold Water Inlet	3/4" NPT
Hot Water Outlet	3/4" NPT
Gas Connection	3/4" NPT
Condensate Outlet	1"

Table 3.2

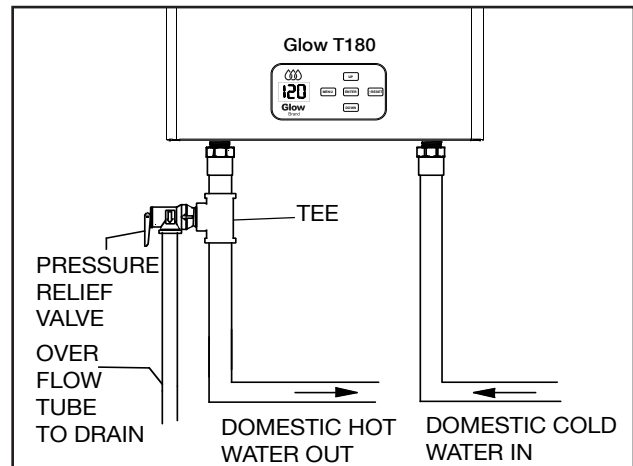

Figure 3.14 - Relief Valve Installation

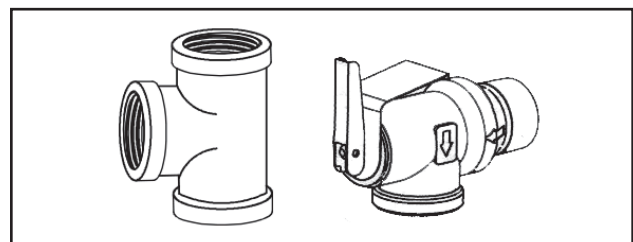

Figure 3.15 - Tee and Pressure Relief Valve

**NOTE: Must be rated for water heater use. The relief valve must have a rating capacity of 500,000 BTU/H and 150/PSI pressure rating. The drawing illustrates a pressure-only relief valve.**

## 3.6.2 Tankless Water Heater Isolation Valve Kit

### Valve Kit

**!** An optional Tankless Water Heater Isolation Valve Kit (fig. 3.16) is intended for installation onto tankless water heater cold inlet and hot outlet connections. Each assembly features union connections, full-port, positive-shutoff ball valve design and integral drain valves with capped hose thread connections. They are available with 3/4" FIP cold inlet and hot outlet connections.

**!** Isolation valves should be installed on the water heater. This will facilitate all maintenance and service operations when the water heater needs to be serviced.

Remove the COLD water isolation inlet valve assembly (identified by the blue handle) from the packaging. Disassemble the union connection by loosening the union nut and removing the tail piece and gasket. Ensure that all components are present: 3/4" NPT tail piece, gasket, union nut and steel nut retaining ring (installed onto the valve's body). **NOTE:** The union nut is permanently mounted to the valve assembly.

Connect the valve assembly's 3/4" NPT to the piping cold water supply line. Use Teflon tape on the pipe nipple's external threads. Use the appropriate flux and solder and verify that the isolation valve is in the open position before sweating onto the copper tubing. Make sure to position the valve assembly in such a way that the handle and purge valve stem are accessible and can be operated without obstruction. Typically, this results in the drain valves capped hose threads facing outward toward the user or to the left, for the COLD isolation valve or right, for the HOT isolation valve.

Use the appropriate thread sealer (Teflon tape), thread and tighten the 3/4" NPT tail piece onto the water heater's COLD water inlet.

Verify that the gasket is centrally positioned onto the tail piece. Reconnect the union nut to the now-installed tail piece. Using the appropriate wrenches, brace the tail piece and tighten the union nut.

Remove the HOT water isolation outlet valve assembly (identified by the red handle) and the pressure relief valve from the packaging. Apply Teflon tape to the male threads of the pressure

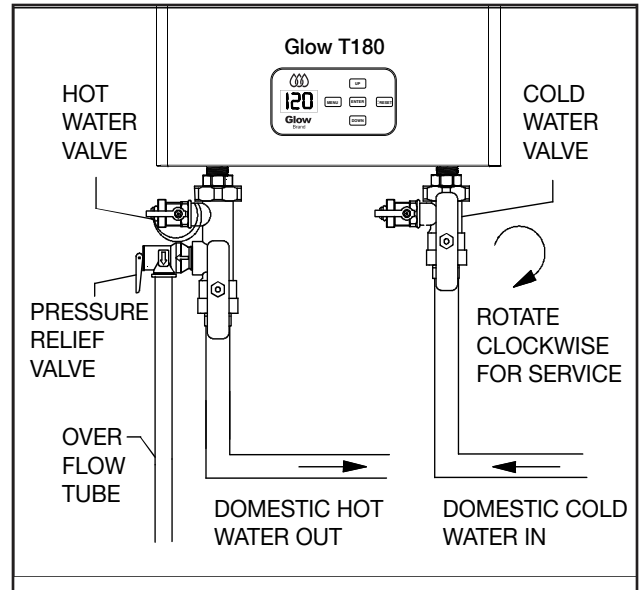

Figure 3.16 - Optional Service Kit

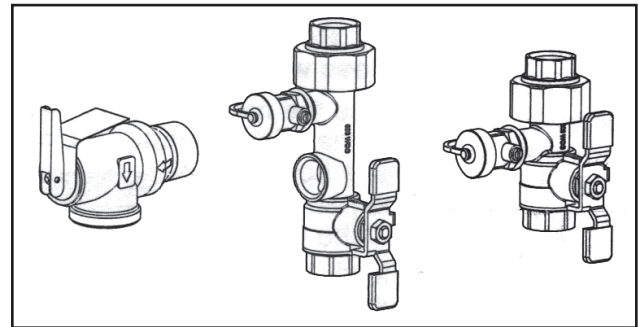

Figure 3.17 - Pressure Relief Valve and Isolation Valves  
**NOTE: Must be rated for water heater use. The relief valve must have a rating capacity of 500,000 BTU/H and 150/PSI pressure rating.**

relief valve. In accordance with the water heater manufacturer's or local code requirements, install and tighten the pressure relief valve into the 3/4" female NPT connection located next to the drain valve. Position the outlet of the pressure relief valve downward.

Repeat the above procedures to install the HOT water isolation outlet valve assembly onto the hot water outlet connection of the water heater.

### 3.6.3 Pressure Relief Valve Installation, Operation and Maintenance



#### **DO NOT PLUG THE PRESSURE RELIEF VALVE!**



When tightening the pressure relief valve into the hot water isolation valve, make sure to place the wrench's jaws on the relief valve's wrench flats. Applying force on any other part of the valve's body may cause irreparable damage.

- Δ Do not install any manually operated shutoff valves between the relief valve's inlet or outlet connections and associated water heater or discharge piping connections. Install the relief valve's inlet connection directly into the tankless hot water heater isolation valve's designated connection only. An unobstructed flow path must exist between the pressure relief valve and water heater in order for the relief valve to function properly.
- Δ The outlet connection of the pressure relief valve must face downward, requiring a vertical discharge pipe. In accordance with IPC code requirement 504.6, install a suitable-length nipple as a discharge pipe, into the female NPT outlet of the pressure relief valve.
- Δ Do not reduce the 3/4" nominal pipe size (NPS) at any length of the piping. The end of the discharge pipe must not be threaded and must remain open and unobstructed.
- Δ The discharge piping must not contain low points, which may trap water. The piping must allow complete drainage.
- Δ The discharge piping must discharge into a suitable open drain and must not be allowed to freeze.

#### **Operation**

In the event that the tankless water heater and its piping system exceed designed pressure limits, the pressure relief valve will automatically open, discharging large amounts of very hot water. Correct installation of the discharge piping and drainage are critical in avoiding a scalding danger or water damage.

#### **Maintenance**

Annually inspect the end of the discharge piping for signs of relief valve leakage. Carefully lift the spring-loaded lever and center it horizontally against the

identification disc, allowing hot water to flow from the end of the discharge pipe, into the drain. **CAUTION!** Discharged water is extremely hot and can scald! Avoid contact with the water. After a few seconds, flip the lever back down, closing the valve. If the pressure relief valve fails to flow water when opened or fails to re-seat when closed, contact a qualified installer for valve replacement.

For safe operation of the water heater, ensure that:

- Δ The pressure rating of the relief valve must not exceed 150psi.
- Δ The BTUH rating on the relief valve must equal or exceed the BTUH input of the water heater.
- Δ No valve of any type should be installed between the relief valve and the water heater.
- Δ Discharge from the relief valve should be piped to a suitable drain. Piping used should be of a type approved for the distribution of hot water.
- Δ The discharge line must be no smaller than the outlet of the relief valve. The drain line must pitch downward to allow for complete drainage of the line.
- Δ The end of the discharge line should not be threaded or concealed and should be protected from freezing. No valve of any type, restriction, or reducer coupling should be installed in the discharge line.
- Δ To prevent vibration and noise coming from the system, do not use pipes of reduced diameter, short radius elbows or severe reductions in the cross sections of the water passages.
- Δ The water flowing out of the pressure relief valve during its operation may be extremely hot. Before operating relief valve, make sure drain line is installed to direct discharge to a safe location such as an open drain. Avoid scalding and/or water damage.

A pressure relief valve is to be installed on the hot water supply outlet line below water heater that is rated in accordance and complying with The Standard for Relief Valves and Automatic Shutoff Devices for Hot Water Supply Systems, ANSI Z21.22 or CSA 4.4 Code.

The pressure relief valve must be installed on the hot water supply line and in such a manner that the discharge is to be piped to a suitable drain for disposal should relief occur. No reducing coupling or other restrictive device is to be installed on the discharge line. The discharge line must be installed to allow complete drainage of both the service valve if installed and the line itself.

### 3.7 Gas Connection



#### 3.7.1 Gas Piping Guidelines

Follow all local codes and/or the most recent edition of the National Fuel Gas Code (ANSI Z223.1/NFPA 54) in the USA or the Natural Gas and Propane Installation Code in Canada (CAN/CSA B149.1).



#### 3.7.2 Gas Supply Lines Pressures

**Note warning applies to this entire section.**

- △ The minimum and maximum inlet gas pressures for Natural Gas - Min. 3.5"WC – Max. 10.00"WC.
- △ The minimum and maximum inlet gas pressures for Liquid Propane Gas Min. 8.00"WC – Max. 13.00"WC.
- △ Gas pressures over and above the specified range will result in adverse performance and dangerous operating conditions; any damage resulting from extreme gas supply pressures will not be covered by the limited warranty.
- △ Until pressure testing of the main gas supply line is completed, ensure the gas line to the **Glow T180** tankless water heater is disconnected to avoid any damage to the water heater.
- △ The appliance and its individual shut off valve must be disconnected from the gas supply piping system during any pressure testing of that system at test pressures in excess of 0.5 psi (3.5 kPa).
- △ The appliance must be isolated from the gas supply piping system by closing its individual manual shut-off valve during any pressure testing of the gas supply system at test pressures equal to or less than 0.5 psi (3.5 kPa).
- △ The gas appliance and its gas connections must be leak tested before placing the appliance in operation. Leaks can be found by using a gas leak detection device or by applying soapy water to all gas fittings. Should bubbles occur, tighten those connections and re-test.
- △ Always purge the gas line for any debris before connecting to the water heater gas inlet.
- △ Never use an open flame to test for gas leaks as property damage, personal injury or death could result.

- △ The maximum inlet gas pressure must not exceed the valve specified by the manufacturer and the minimum valve listed for the purposes of input adjustment.
- △ The connection to the gas supply must be carried out by professionally qualified personnel in accordance with the relevant standards.
- △ Check the internal and external seals of the gas supply system.
- △ A gas shut-off valve must be installed upstream of the appliance.
- △ Before starting up the water heater, make sure that the type of gas corresponds to that for which the appliance has been set-up.
- △ The gas supply pressure must be between the values reported on the rating plate.
- △ If the power supply wire is damaged in any way, switch off the appliance and have the wire replaced by a qualified electrician.

#### **When using an electrical appliance:**

- △ Do not touch the appliance with damp or wet parts of the body or when barefoot.
- △ Do not pull on the electric wires.
- △ Do not allow the appliance to be used by children or anyone unfamiliar with its operation.

### 3.8 Electrical Connections

#### 3.8.1 General Warnings



Follow the electrical code requirements of the local authority having jurisdiction. In the absence of such requirements, follow the latest edition of the National Electrical Code (NFPA 70) in the U.S. or the latest edition of CGA C22.1 Canadian Electrical Code – Part 1 in Canada.



### 3.8.2 Electrical Wiring: Ground And Surges

- △ All units come with a factory installed 3-pronged (grounded) 120 VAC plug. The tankless water heater can be plugged into any standard electrical duplex outlet close to the unit as it requires only 1 Amp. Always check to make sure that the appliance is securely grounded.
- △ This requirement is only satisfied if it has been properly connected to an efficient ground system installed in accordance with the requirements of current safety standards and carried out by professionally qualified personnel.
- △ The tankless water heater must be electrically grounded. Ensure the electrical receptacle, in which the water heater will be plugged into, is properly grounded; if wiring directly, do not attach the ground wire to either the gas or the water piping as plastic pipe or dielectric unions may isolate the water heater electrically.
- △ The use of a surge protector is recommended to protect from power surges.
- △ Do not power the unit until all plumbing and gas piping is complete and the unit has been filled with water.
- △ The electrical voltage required by the water heater is 120VAC at 60Hz with a maximum 1 Amp rating with proper grounding. **DO NOT** apply 220-240VAC or any other voltage to this unit. This will damage the water heater and void the warranty.
- △ Do not disconnect the power supply when the unit is in normal operation.
- △ If there is a power failure in cold weather areas, the freeze prevention system in the water heater will not operate and may result in freezing of the heat exchanger; in cold weather areas where power failures are common, you must completely drain the unit to prevent damage if the power will be off for any extended period of time.
- △ Damage caused by freezing is not covered under warranty.
- △ **CAUTION** : Label all wires prior to disconnection when servicing controls. Wiring errors can cause improper and dangerous operation. Verify proper operation after servicing.
- △ The connection to the main power supply must be carried out by professionally qualified electrical personnel, registered in accordance with current legislation and local authorities.
- △ Always check to make sure that the appliance has a sufficient ground. This requirement is only satisfied if it has been properly connected to an efficient ground system installed in accordance with the requirements of current safety standards and carried out by professionally qualified personnel.
- △ This basic safety measure must be checked, verified and carried out by professionally qualified personnel.

**Have the electrical system checked by a qualified electrician. The manufacturer will not be held liable for any damage or injury caused as a result of an inefficient or faulty ground system.**

**If the unit fails to re-start after any fault, unplug the unit for 30 seconds, then re-plug in the unit and try to restart with the ON/OFF switch. If the unit fails to restart, call a qualified technician for service.**

- △ Ensure the domestic power supply is checked by a qualified electrician to ensure that it can support the maximum power absorption of the appliance, as indicated on the rating plate. In particular, make sure that the cable sizes are adequate for the power absorbed by the appliance;
- △ The power supply cable must be replaced by a qualified electrician. If the cable is damaged in any way, switch off the appliance and have the cable replaced by a suitably qualified electrician;
- △ When using an electrical appliance, a few fundamental rules must be observed:
- △ **DO NOT** touch the appliance with damp or wet parts of the body or when barefoot.
- △ **DO NOT** pull on the electric wires.
- △ **DO NOT** allow the appliance to be used by children or anyone unfamiliar with its operation.

### 3.9 Venting



Improper venting of this tankless water heater can result in excessive levels of carbon monoxide which can result in severe personal injury or death. This water heater must be vented in accordance with the “Venting of Equipment” section of the latest edition of the ANSI Z223.1 / NFPA 54 Natural Gas Code and/or the “Venting systems and air supply for appliances” section of the latest version of the CAN/CSA B149.1 Natural Gas and Propane Installation Code in Canada and in accordance with all applicable local building codes.

#### 3.9.1 Venting Guidelines

- △ For best results, keep the vent system as short and straight as possible.
- △ Locate the tankless water heater as close as possible to the vent termination.
- △ The water heater vent must not be common vented with any other gas appliance or vent stack.
- △ Slope vent upwards towards the vent terminal at a minimum rate of 1/4” per foot (2% slope).
- △ Vent termination must be a minimum of 12” above grade or expected snowfall.
- △ Vent and air intake pipe must be supported every 4 feet of horizontal run and every 5 feet of vertical run.

#### 3.9.2 Glow T180 And Direct Vent

- △ All **Glow T180** tankless water heaters are manufactured as a direct vent unit (sealed combustion), which draws combustion air directly from outside the building.
- △ This **Glow T180** water heater uses a 3” diameter exhaust and 3” diameter air intake pipe.
- △ The air intake vent materials can be made of Schedule 40 ABS, PVC, or CPVC materials and in accordance with all applicable local building codes.

#### 3.9.3 Contaminated Make-Up Air Will Damage The Unit

- △ Recommend not to operate the tankless water heater in an area that is or will be under construction or renovation.
- △ The **Glow Brand** warranty will not cover damage and premature wear caused to the unit due to installation in a contaminated environment.

- △ All of the exhaust venting connections must be leak checked with a soap solution upon initial startup of the water heater. Any leaks must be repaired before continuing operation of the water heater.
- △ Warranty will not be available if the water heater is used for construction heat.

#### 3.9.4 Exhaust Vent Piping Materials

- △ Use only 2”, 2 1/2”, or 3” solid PVC/CPVC schedule 40 PVC/CPVC or ULC S636 pipe and fittings.
- △ Venting requirements in USA and Canada are different. Please consult with the most recent edition of the National Fuel Gas Code (ANSI Z223.1 / NFPA 54) or CAN/CSA B-149.1 as well as local codes for applicable venting regulations and restrictions.
- △ For installation in Canada, field supplied plastic vent piping must comply with CAN/CSA B-149.1 (latest edition) and be certified to the standard for type BH Gas Venting Systems. ULC S636 components of this listed system shall not be interchanged with other vent systems or unlisted pipe/fittings. All plastic components and specified primers and glues of the certified vent system must be from a single manufacturer and not intermixed with other system manufacturer’s vent system parts. The supplied vent adapters are certified as part of the water heater.
- △ Units installed with vertical exhaust, must have an additional approved condensate drain installed on the horizontal section of the exhaust vent. Fittings must be ULC S636 approved.
- △ Schedule 40 PVC/CPVC pipe/fittings have been approved for use on this appliance with zero clearance to combustibles.
- △ This water heater requires a special venting system. Refer to the installation instructions for parts list and method of installation.
- △ Use of cellular core Schedule 40 PVC (ASTM F891), cellular core CPVC, or Radel (polyphenylsulfone) in non-metallic venting systems is prohibited. Covering non-metallic vent pipe and fittings with thermal insulation is prohibited.

**3.9.5 Intake Vent Pipe Materials**

- Δ Schedule 40 PVC, CPVC or ULC S636 pipe and fittings and ABS pipe and fittings can be used for combustion air intake on **Glow Brand** products.
- Δ Transition cement must be used if ABS pipe is connected to the PVC appliance adapters.
- Δ All plastic components and specified primers and glues of the certified vent system must be from a single manufacturer and not intermixed with other system manufacturers vent system parts.
- Δ The vent for this appliance shall not terminate over public walkways, near soffit vents, crawl spaces or other areas where condensate or vapour could create a nuisance or hazard or cause property damage or where condensate vapour could cause damage or could be detrimental to the operation of regulators, relief valves of other equipment.

<b>Available Vent Lengths</b>	
<b>Model</b>	Glow T180
<b>Size</b>	2", 2 1/2" or 3" Diameter
<b>Max Equivalent Length Vertical and Horizontal per Vent Run</b>	2" Diameter =25ft 2 1/2" Diameter =50ft 3" Diameter =100ft
<b>Type</b>	Natural Gas/ Liquid Propane
<b>Exhaust Vent</b>	Schedule 40 PVC/ CPVC
<b>Intake Vent</b>	Schedule 40 PVC, CPVC or ABS

Table 3.3

**Equivalent Lengths**

- Δ Reduce the maximum vent length accordingly for each elbow used.
- Δ Each 3" 45° elbow equates to 2.5 linear feet of vent pipe.
- Δ Each 3" 90° short radius elbow equates to 7.5 linear feet of vent pipe.
- Δ Each 3" 90° long radius elbow equates to 5 linear feet of vent pipe.
- Δ The maximum length listed is for exhaust vent only. The intake length should be equal length.
- Δ The total maximum equivalent vent pipe distance cannot exceed 100ft for horizontal and vertical venting distance.
- Δ The maximum lengths include elbows.
- Δ Exceeding the maximum venting distance may cause the appliance to malfunction or cause an unsafe condition.

**Minimum Vent Lengths**

- 2" Diameter - 6" pipe (Length) plus one elbow.
- 2 1/2" Diameter - 6" pipe (Length) plus one elbow.
- 3" Diameter - 6" pipe (Length) plus one elbow.

3.10 Venting Diagrams

3.10.1 Venting Clearances - Direct Vent

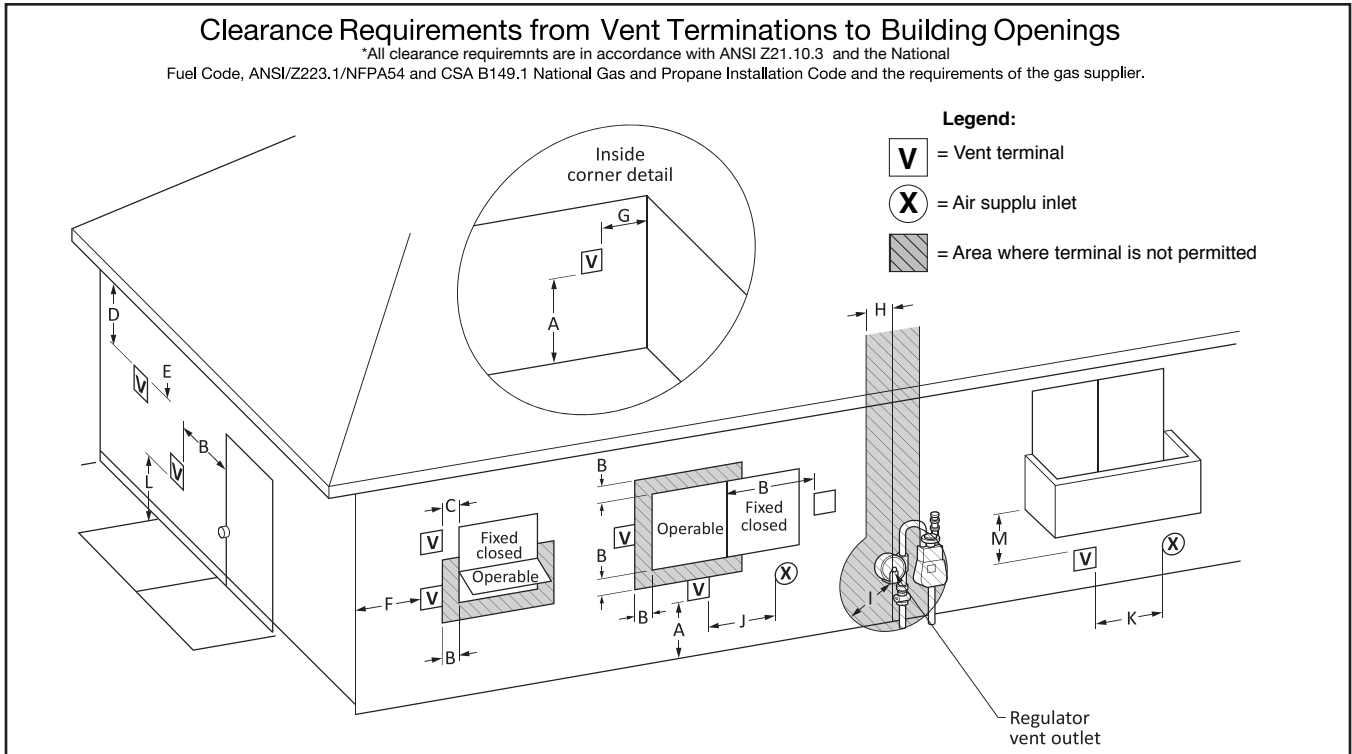

		Canadian Installations <sup>1</sup>	US Installations <sup>2</sup>
A	Clearance above grade, veranda, porch deck or balcony	12 in (30 cm)	12 in (30 cm)
B	Clearance to window or door that may be opened	6 in (15 cm) for appliances ≤ 10,000 BTUh (3kW), 12 in (30cm) for appliances > 10,000 BTUh (3kW) and < 100,000 BTUh (30kW), 36 in (91 cm) for appliances > 100,000 BTUh (30kW)	6 in (15 cm) for appliances ≤ 10,000 BTUh (3kW), 9 in (23 cm) for appliances >10,000 BTUh (3kW) and ≤ 50,000 BTUh (15kW), 12 in (30 cm) for appliances > 50,000 BTUh (15kW)
C	Clearance to permanently closed window	*	*
D	Vertical clearance to ventilated soffit located above the terminal within a horizontal distance of 2 feet from the center of the terminal	*	*

Table 3.4

(continued)



		<b>Canadian Installations<sup>1</sup></b>	<b>US Installations<sup>2</sup></b>
E	Clearance to unventilated soffit	*	*
F	Clearance to outside corner	*	*
G	Clearance to inside corner	*	*
H	Clearance to each side of centre line extended above meter / regulator assembly	*	*
I	Clearance to service regulator vent outlet	Above a regulator within 3 ft (91 cm) horizontally of the vertical center line of the regulator vent outlet to a maximum vertical distance of 15 ft (4.5 m)	*
J	Clearance to non mechanical air supply inlet or combustion air inlet to any other appliance	6 in (15 cm) for appliances ≤ 10,000 BTUh (3kW), 12 in (30cm) for appliances > 10,000 BTUh (3kW) and < 100,000 BTUh (30kW), 36 in (91 cm) for appliances > 100,000 BTUh (30kW)	6 in (15 cm) for appliances ≤ 10,000 BTUh (3kW), 9 in (23 cm) for appliances >10,000 BTUh (3kW) and ≤ 50,000 BTUh (15kW), 12 in (30 cm) for appliances > 50,000 BTUh (15kW)
K	Clearance to mechanical air supply inlet	6 ft (1.83 m)	3 ft (91 cm) above if within 10 ft (3 m) horizontally
L	Clearance above paved sidewalk or paved driveway located on public property	7 ft (2.13 m) <sup>+</sup>	*
M	Clearance under veranda, porch deck or balcony	12 in (30 cm) <sup>++</sup>	*

Table 3.4 (continued)

\* For clearances not specified in ANSI Z223.1/NFPA 54 or CSA B149.1, one of the following shall be indicated:

- A) a minimum clearance value determined by testing in accordance with Clause 5.21, Draft hoods, or
- B) a reference to the following footnote:

“Clearance in accordance with local installation codes and the requirements of the gas supplier.”

+ A vent shall not terminate directly above or sidewalk or paved driveway that is located between two single family dwellings and serves both dwellings.

++ Permitted only if veranda, porch, deck, or balcony is fully open on a minimum of two sides beneath the floor.

Notes:

- 1) In accordance with the current CSA 8149.1, Natural Gas and Propane Installation Code
- 2) In accordance with the current ANSI Z223.1/ NFPA 54, National Fuel Gas Code

3.10.2 Venting Materials

VERTICAL VENT TERMINATION - PVC/CPVC MATERIAL ONLY 2", 2½" OR 3"

VERTICAL INTAKE - ABS OR PVC/CPVC MATERIAL 2", 2½" OR 3"



OPTIONAL COUPLING OR 45° ELBOW WITH OPTIONAL 1/2" x 1/2" GALVANIZED SCREEN (SUPPLIED BY MANUFACTURER) INTO EXHAUST END

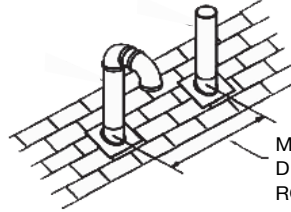

MINIMUM 24" APART IN ANY DESIRED POSITION ON THE ROOF

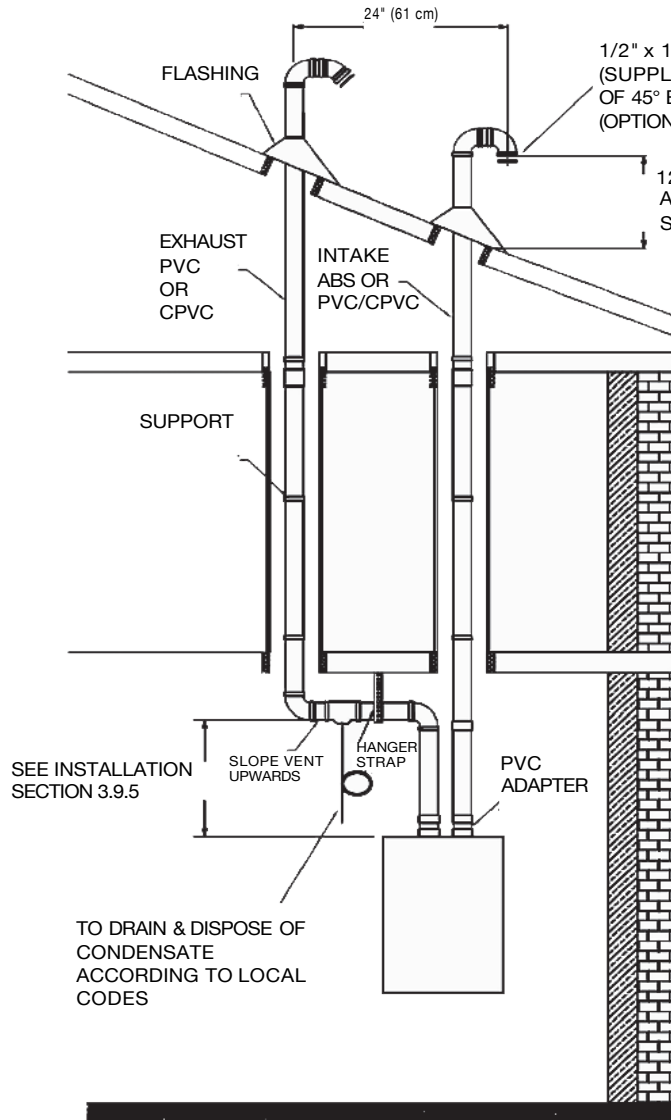

\* THE AIR INLET AND EXHAUST PIPE CAN BE LOCATED IN ANY DESIRED POSITION ON THE ROOF, BUT MUST ALWAYS BE MINIMUM 24" APART.

A PROPER FLASHING SHOULD BE USED TO SEAL THE PIPE WHERE IT EXITS THE ROOF.

THE VENT SYSTEM MUST TERMINATE SO THAT THE PROPER CLEARANCES ARE MAINTAINED AS CITED IN LOCAL CODES OR THE CURRENT EDITION OF THE NATURAL GAS AND PROPANE INSTALLATION CODE (CAN/CSA-B-149.1) AND ANSI Z223.1/NFPA54.

PROVIDE SUPPORT FOR ALL PIPE PROTRUDING THROUGH THE ROOF. ALL PIPEING SHOULD BE SECURED. THE VENT SYSTEM SHOULD BE SUPPORTED EVERY 5 FEET (1.5m) OF VERTICAL RUN AND EVERY 3 FEET (1.0m) OF HORIZONTAL RUN. ALL PIPING AND FITTINGS MUST BE JOINED BY THE PROPER PROCEDURES AS DESCRIBED UNDER VENT PREPARATION.

WHEN USING A HORIZONTAL SECTION, SLOPE THE HORIZONTAL VENT 1/8" UPWARDS TOWARDS FOR EVERY 12" (30 cm) (1% SLOPE) TOWARDS THE TERMINATION TO THE DRAIN CONDENSATE.

EXHAUST VENT PIPE THROUGH AN UNHEATED SPACE MUST BE INSULATED AS PER LOCAL CODES AND AUTHORITIES.

\* ALL VERTICAL EXHAUST VENTING MUST HAVE AN ADDITIONAL CONDENSATE DRAIN. ALL FITTING MUST BE ULC S636 APPROVED.

**3.10.3 Horizontal Venting**

HORIZONTAL VENTING - PVC/CPVC/ABS MATERIAL ONLY 2", 2½", or 3"

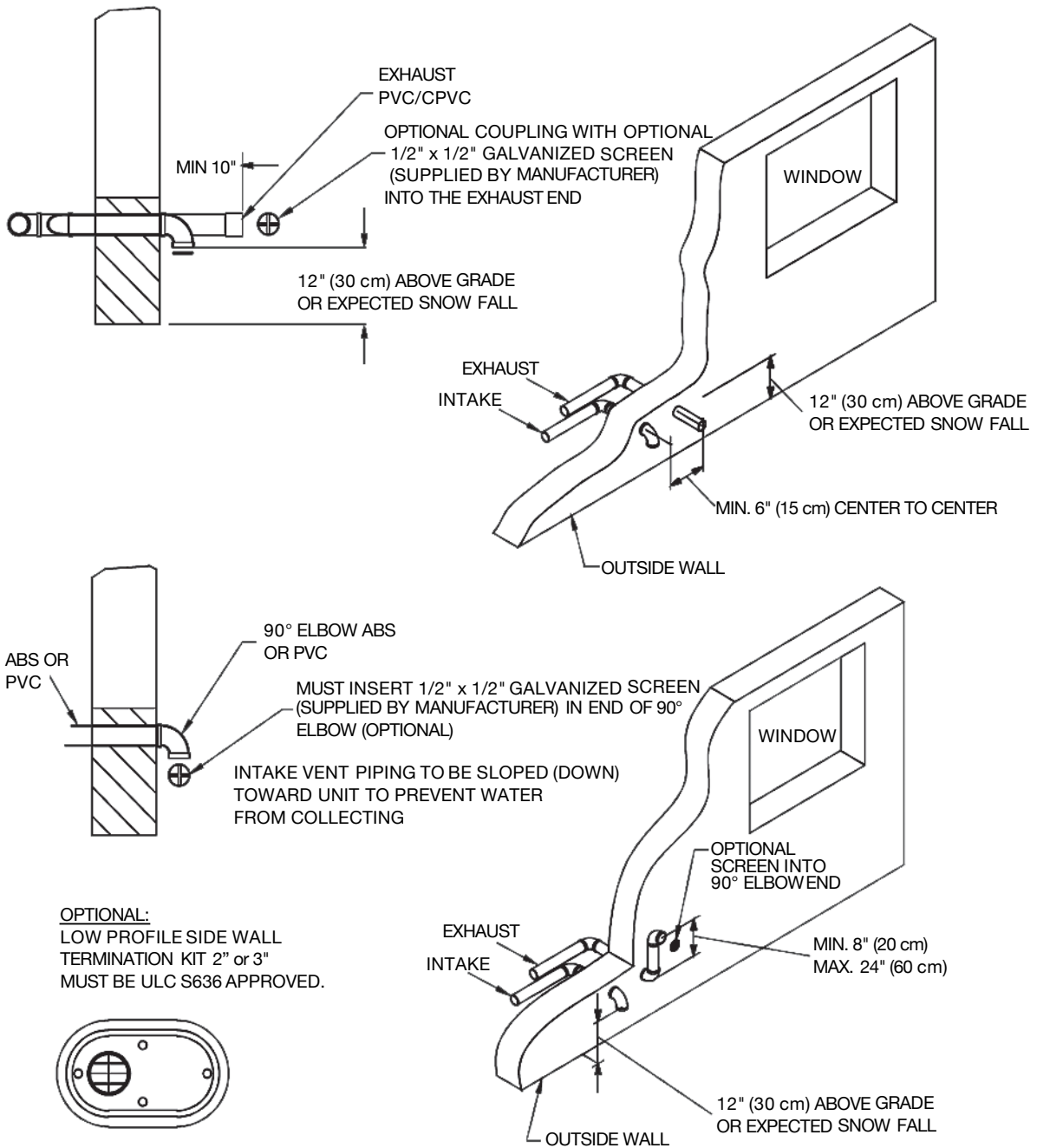

3.10.4 Concentric Vent Termination

CONCENTRIC VENT TERMINATION - 2" or 3" PVC

	Dimensions (inches)				
	A	B	C	Nominal Pipe Size	
				D	E
2" Concentric Kit	29	16.5	3.5	2	2
3" Concentric Kit	36.1	20.5	4.5	3	3

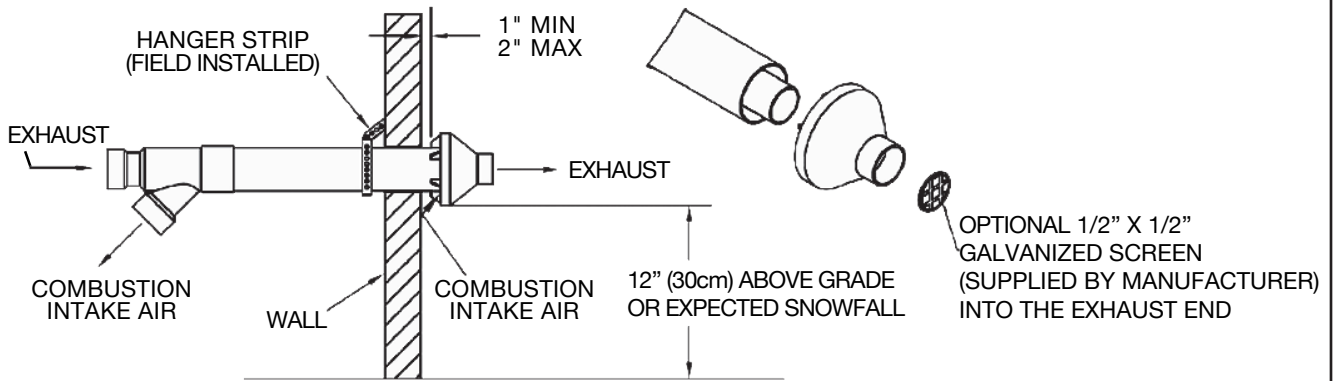
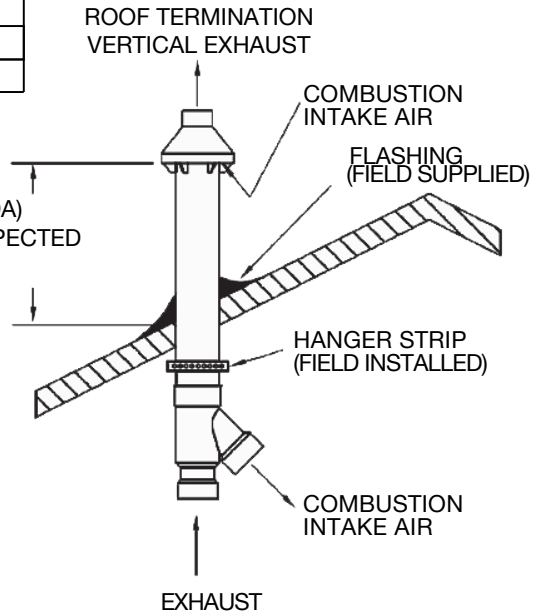
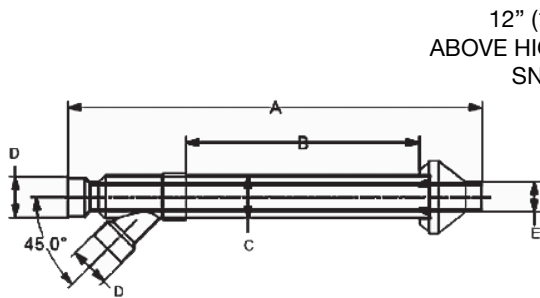

NOTE: USE ONLY ULC S636 APPROVED CONCENTRIC VENT TERMINATION - 2" or 3" PVC

3.10.5 Concentric Vent Termination

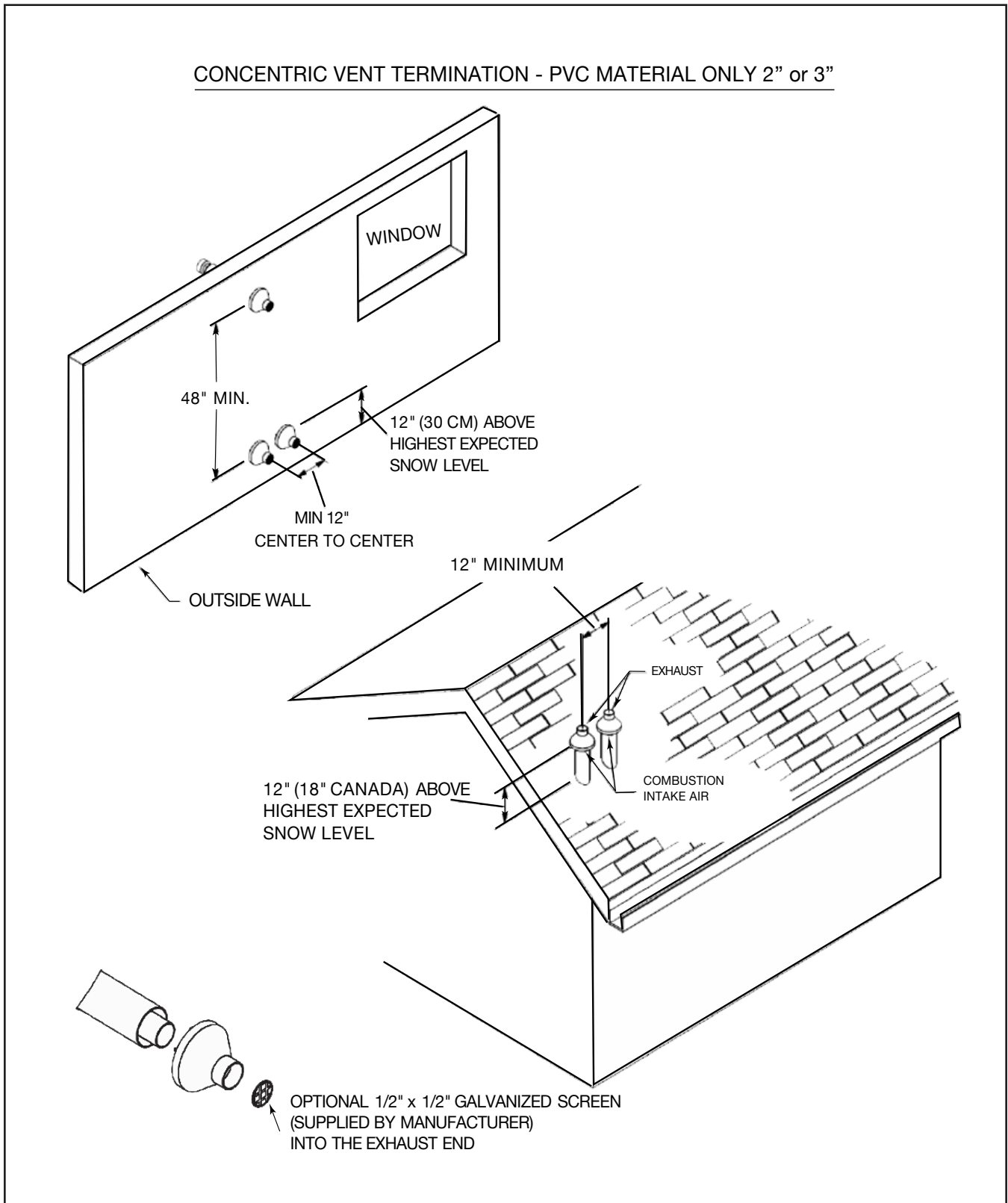



## 4. Commissioning The Appliance

### 4.1 General Warnings

 The following operations must be carried out by professionally qualified personnel, registered in accordance with current legislation.

 Warranty will not be covered if unit is not commissioned by a certified **Glow Brand** contractor.

 The water heater leaves the factory preset and tested for burning either natural Gas or LPG. Nevertheless, prior to starting the water heater for the first time, make sure that the information on the rating plate corresponds to the type of gas being supplied to the water heater.

 Once the system has been filled and the necessary adjustments made, remember to tighten the screws of the gas valve test port and make sure that there are no gas leaks from the test port and from any pipe fittings upstream of the gas valve.

### 4.2 Preliminary Operations

Switching the water heater on for the first time means checking that the installation, regulation and operation of the appliance are correct.

- △ Check that the rating on the rating plate corresponds to that of the main supply networks (gas, electricity, water).
- △ Check that the power supply voltage to the water heater complies with the rating plate (120 V – 60 Hz) and that the live, neutral and ground wires are connected properly. Also make sure that the ground connection is sound.
- △ Check that the gas supply is correctly sized for the flow rate required by the water heater and that it is fitted with all the safety and control devices stipulated by current regulations.
- △ Check that the supply of combustion air and exhaust and condensate discharge systems are functioning correctly and in line with current law and national and local standards.
- △ Check for the presence of permanent aeration/ventilation openings as required by current law for the type of appliances installed.
- △ Check that the exhaust vent and its connections to the termination comply with the requirements of current law and national and local standards for the type of appliances installed.
- △ Check that the condensate drain system, including outside the water heater (exhaust system condensate collection devices), allows the condensate to flow freely to the drain.

- △ Check that there are no flammable materials or liquids in the immediate vicinity of the water heater.

### 4.3 Flushing The System

**Failure to flush the system will invalidate the appliance warranty.**

**All systems must be thoroughly drained and flushed out using additives or flushing agents/de-scalers. All flushing must be done for new and retrofit installs.**

 **Warning: Failure to clean the system invalidates the warranty.**

**To flush out domestic hot water circuit:**

1. Open all hot water outlets and airhandler drain cocks. (if so equipped)
2. Open the main water valve to allow water to enter the water heater; allow water to flow. Leave to fill until water is released from the hot water outlets. Turn off all hot water outlets.
3. Connect a hose pipe to the cylinder drain cock and open the drain cock.
4. Allow water to flow through the water heater and air handler and out of the drain cock. (if so equipped)
5. Turn off water supply, disconnect the hosepipe, close the drain cock and refill the water heater and air handler. (if so equipped)

### 4.4 Priming The Condensate Trap

The condensation trap must be filled when starting the water heater for the first time in order to prevent flue gases from flowing back through the trap. (see figure 4.1)

**Attention!** It is recommended to clean the condensate trap, after a few months of water heater operation, to remove deposits/residuals left after the first condensate passage within the water heater new components that may interfere with the correct operation of the trap itself.

Remove the condensate trap and clean it with a soapy solution.

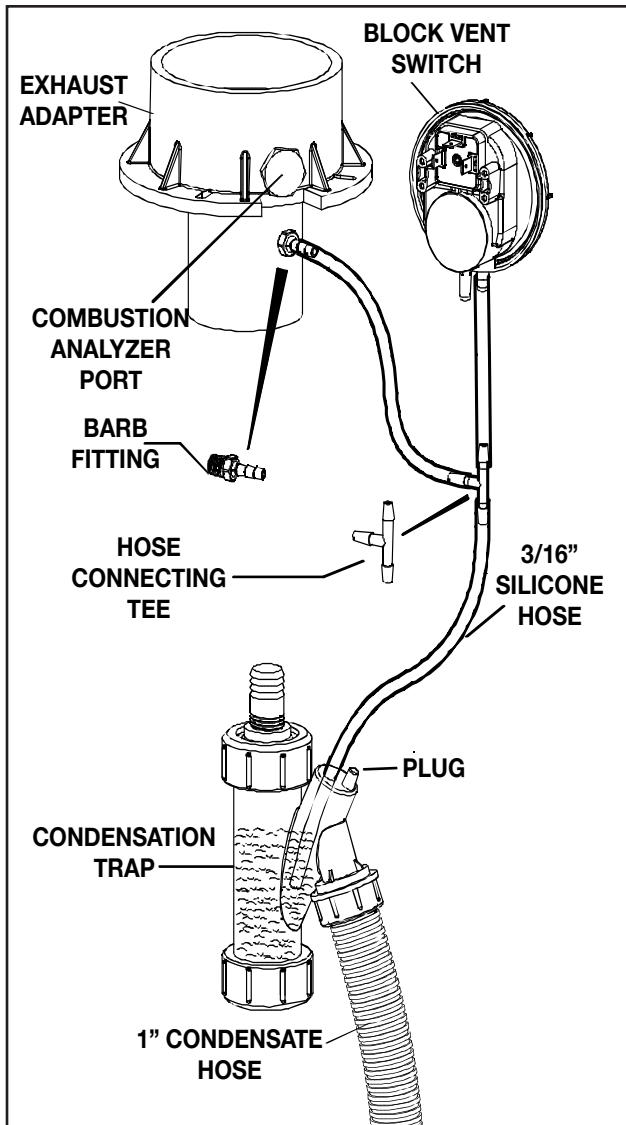

Figure 4.1 - Condensate trap connections

## 4.5 Starting Up The Water Heater

Once the system has been filled, proceed as follows:

- Δ Check that the exhaust flue is free of obstructions and correctly connected to the water heater.
- Δ Plug the power cord of the water heater into the wall receptacle and make certain the unit is operational.
- Δ Open the gas cock supplying the unit.
- Δ Create a call for hot water by opening a hot water faucet; The faucet icon will start to flash and a flame icon will appear.
- Δ The automatic ignition system will attempt to

light the burner. This operation is repeated for 3 times. It may be necessary to repeat the operation in order to eliminate all the air from the gas line. To repeat the operation, wait approximately three minutes before reattempting to light the water heater. To reset the water heater, press the [RESET] button and hold for 3 seconds then release.

## 4.6 Gas Valve And Set Up

This water heater has been set up from the factory for normal operation, however it is required to complete a system check of the components and preform a combustion analysis prior to completing the installation. The system check consists of the following:

- Δ Check and measure the gas pressure available from the source. 7" w.c. is the nominal pressure required for (NG), 11" w.c. (LP).
- Δ Check and ensure that 120v is available at the outlet
- Δ Check for correct polarity
- Δ Ensure the hot and cold water supplies are piped correctly to the water heater.
- Δ Ensure the relief tube is piped to the pressure relief valve and the condensate hose is to a drain
- Δ Either a service valve kit or a tee and relief valve is to be installed on the water heater
- Δ Once the unit has be plugged in, verify that all safety devises are operational (hi limit switch, micro fuse, blocked flue sensor, see Section 5.5)
- Δ Once a demand for hot water is made, sounds emitted from the heat exchanger are normal until all air has been eliminated from the heat exchanger
- Δ The water heater must be operating at maximum capacity in order to complete a combustion analysis (see adjusting the throttle).

**4.7 Adjusting The Gas Throttle**

Each **Glow T180** unit is factory set to operate with Natural Gas or Liquid Propane. These units cannot be field converted.

When installing the water heater, it may be necessary to adjust the throttle on the gas valve to ensure a correct and efficient operation. This can be done by inserting a 2 mm allen key into the throttle adjustment screw on the gas valve. Turning this screw right or left will change the CO<sub>2</sub> value measured by the combustion analyzer. See Figure 4.3 for the throttle adjustment locations.

**Throttle Adjustment**

Turn adjustment screw clockwise to decrease CO<sub>2</sub> value



Turn adjustment screw counter clockwise to increase CO<sub>2</sub> value



Figure 4.2 - Throttle adjustments

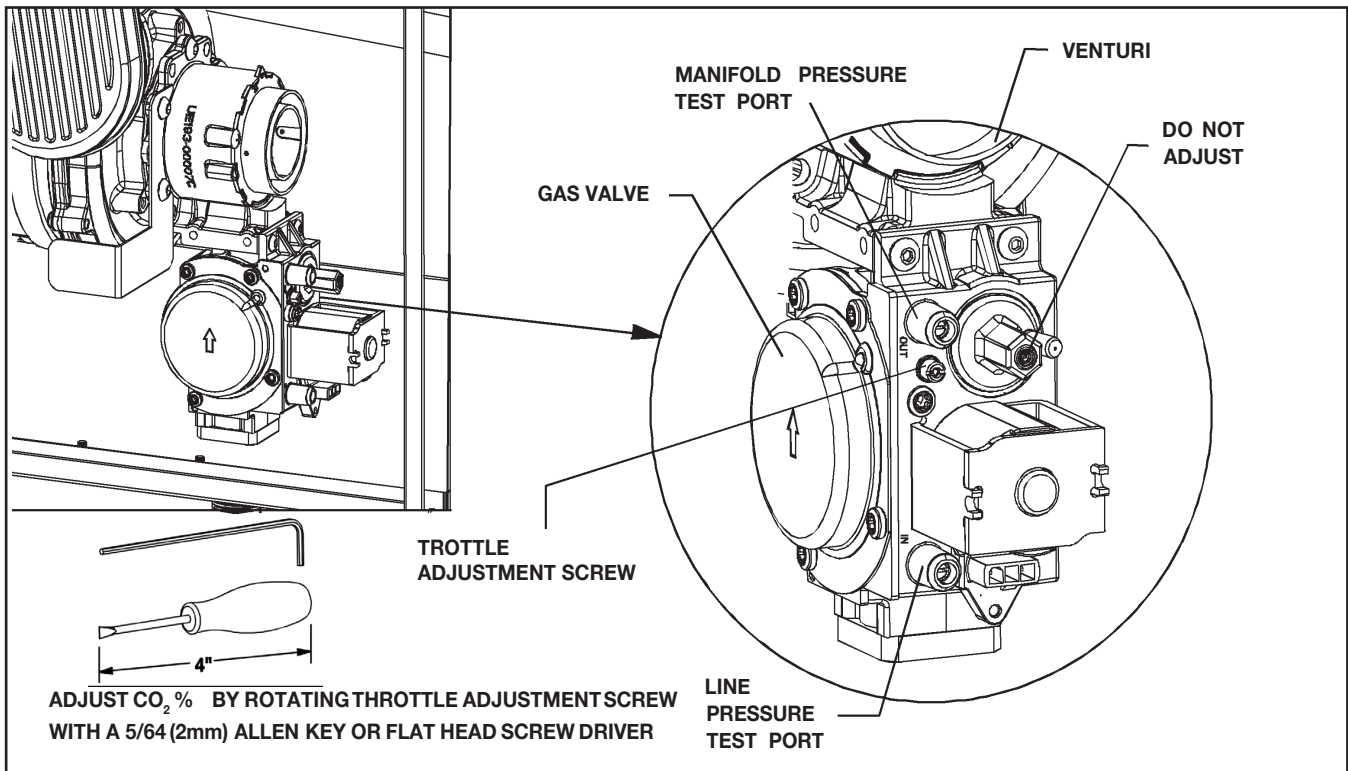

Figure 4.3 - Throttle adjustment locations

**NOTE:**

The unit should be operating at maximum capacity for 5 minutes prior to adjusting the throttle.



**Adjustment (NOTE: A properly calibrated combustion analyzer must be used.)**

Δ Flow maximum water through heater by opening laundry or bathtub faucet. Set heater to its maximum capacity using following steps.

1. Enter the Service Menu	2. Scroll through Parameter List	3. Select parameter	4. Alter value of parameter	5. Confirm / cancel alteration
Hold [MENU] button for 5 sec.	Scroll through the parameter list with the [UP] / [DOWN] buttons.	Select a parameter <b>210</b> value by pressing [ENTER].	Alter a value of the parameter with the [UP] / [DOWN] buttons to <b>Hig.</b>	Confirm (save) with [ENTER] or Cancel with [RESET].

Table 4.1

Δ If the CO<sub>2</sub> value does not correspond to the specified range, (As indicated in the Specifications Table below), turning the throttle screw clockwise will reduce the flow of gas as it enters the gas train thereby reducing the CO<sub>2</sub> value allowing for a leaner fuel mixture. Turning the screw counter clockwise will increase the flow of gas resulting in a higher CO<sub>2</sub> value.

GAS TYPE	GAS PRESSURE (INCHES W.C.)			CO <sub>2</sub> %			CO (ppm)
	Nominal	Min .	Max.	Nominal	Min .	Max.	Max.
Natural Gas	7	3.5	10.5	9.2	8.8	9.8	200
Liquid Propane	11	8	13	10.5	10.0	11.0	200
<b>Frequency</b>							
Gas Type	Minimum (RPM)			Maximun (RPM)			
Natural Gas/Propane	1450			8200			

Table 4.2

- Δ It may be necessary to set the throttle to the higher value within the range for longer vent lengths while setting to the lower value range for short vent lengths.
- Δ Only the line test ports and the throttle adjustment screws are to be affected as required. All other screws do not need to be touched since they are preset at the factory. Failure to do so may result in erratic and unreliable burner operation, increased fuel consumption leading to reduced efficiency and general unsafe operation. Failure to follow these instructions may result in serious injury
- Δ Recycle the main supply power to bring the heater to its normal condition.
- Δ CO readings should be under 200 ppm. Consult factory if readings exceed 200 ppm.

**4.8 Set Point Temperature (When utilized for Space Heating)**

The temperature setpoint cannot exceed 145°F when in **ECO** or **Comfort Mode** and/or connected to a space heating source that utilizes an automatic DHW flush cycle. Cycle duration should not exceed 5 minutes every 24 hours. Failure to set properly may result in A16 Lock-out.

**5. Maintenance (Authorized Personnel)**

**! 5.1 General Warnings**

- Δ All maintenance operations must be carried out by professionally qualified personnel, authorized by **Glow Brand**.
- Δ The frequency of water heater maintenance is recommended to be carried out once a year.
- Δ In order to guarantee the long life of the appliance and in accordance with the current gas safety regulations, only use original OEM parts.
- Δ Before carrying out any type of maintenance operation, disconnect the appliance from the electrical supply and shut off the gas valve.
- Δ Warranty will not be offered if recommended maintenance is not followed.
- Δ Remove and clean any deposits from the burner.
- Δ Check that the seal of the room-sealed chamber is undamaged and positioned correctly.
- Δ Check the heat exchanger and clean if necessary.

**! 5.2 Maintenance**

- Δ Periodic examination of the entire venting system is recommended.
- Δ Ensure all venting connections/joints are tight and in good condition where visible.
- Δ Remove the burner along with the motor and gas valve as one complete assembly.
- Δ When doing so, visually inspect the burner and components for signs of wear or irregular characteristics. This would include the ignition and ionization.
- Δ Reassemble the complete burner assembly.
- Δ Visually inspect the burner flame. The flame must burn with a clear blue, stable flame when in operation.
- Δ All electric motors are permanently lubricated and do not need oiling.
- Δ Verify proper operation after any servicing.
- Δ Wipe the outside surface with a wet cloth; then dry the surface.
- Δ Vent termination should be inspected for blockage during maintenance checks.
- Δ Check for blockage at the drain pipe and condensate trap.
- Δ Check for water leaks from the equipment and piping.
- Δ Warranty will not be offered if recommended maintenance is not followed.

**! CAUTION!** Before pressurizing the system for service, **ALWAYS** make sure the drain valves of both **HOT** and **COLD** isolation valve assemblies are placed in the **CLOSED** position, where the drain valves' stem slot is positioned perpendicular to the drain valves' body. **Remove the hose caps and visually inspect the drain valve outlets to verify that the balls are in the closed position. You should see the chrome-plated face of a closed ball. You should NOT be able to see into the body of the drain valve. Replace the hose caps and hand-tighten only.**

**5.3 De-scaling and flushing**

**! CAUTION!** Before unthreading the hose caps for any reason, make sure the drain valves are **CLOSED**. **Unthread slowly, to allow any built-up pressure to disperse. After removing the cap, inspect the cap's gasket for damage. Replace as necessary.**

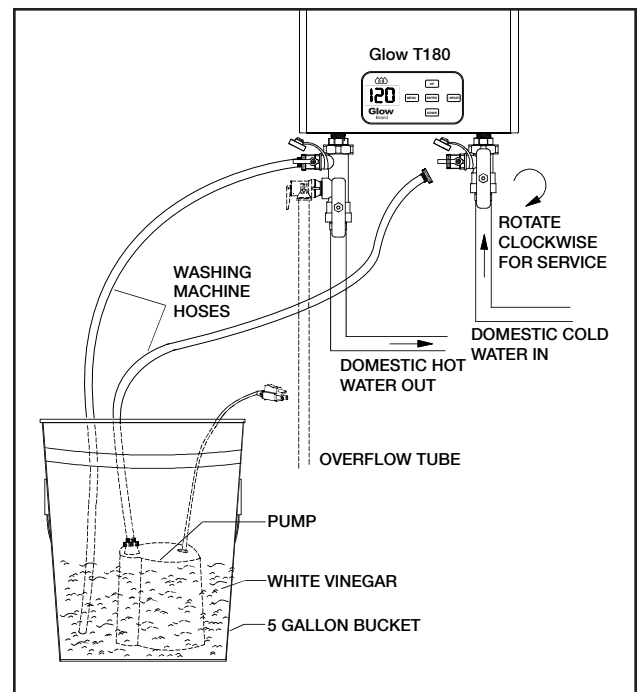



Figure 5.1 - Flushing the water heater

 **Isolation valve handles should be in the FULL-OPEN position under normal operating conditions. Both red and blue handles should be parallel with the valve body and piping or tubing.**

**The following steps are required when de-scaling and flushing the tankless water heater. (fig. 5.1)**

- Δ Both HOT outlet and COLD inlet isolation valves must be closed whenever the HOT and COLD drain valves are uncapped and opened.
- Δ Before removing the tethered caps of the drain valves to attach hoses, ALWAYS verify that the drain valves are completely closed. The tethered caps are designed to keep debris from entering the drain valves' ends. They are not designed to contain continuous pressure.
- Δ Flushing and de-scaling involves connecting a pump that is submerged in a bucket of vinegar to the water heater via hoses, and circulating vinegar through the heat exchanger. Any scaling inside the heat exchanger will exit and collect inside bucket.
- Δ Prior to operating the pump, the main isolating valves for the HOT and COLD water must be closed.
- Δ Open the service valves and activate the pump allowing white vinegar to circulate through the heat exchanger for approximately 20 minutes.
- Δ Close the COLD water service valve and open the COLD water isolation valve and allow fresh water to circulate through the heat exchanger while exiting from the HOT water service port into the bucket.
- Δ Close the HOT water service valve and open the HOT water isolation valve and restore to normal operating conditions. When both isolation valve handles are in the open position, water is present at the drain valves. Therefore, both HOT and COLD drain valves MUST remain closed and capped during system operation!
- Δ It may be necessary to clean the Inlet Water Screen once the flushing procedures have been completed.
- Δ Annually inspect all connections for signs of leakage. Correct as necessary.

## 5.4 Water Heater Inspection

In order to ensure that the water heater operates efficiently and safely, it is recommended that the appliance is inspected by an authorized technician at least once a year.

The following operations should be carried out annually:

- Δ Check the condition of the gas seals and replace where necessary.
- Δ Check the condition of the water seals and replace where necessary.
- Δ Visually inspect the condition of the combustion chamber and flame.
- Δ When required, check that the CO<sub>2</sub> is set to the specified range as listed in the section 4.6 Adjusting the gas Throttle.
- Δ Check the condition and operation of the ignition and gas safety systems. If necessary, remove and clean the scaling from the ignition and flame detection electrodes, paying particular attention to place them at the correct distance from the burner.
- Δ Check the heating safety systems: temperature limit safety thermostat, pressure limit safety device.
- Δ For safety reasons, periodically check the integrity and operation of the exhaust system.
- Δ Check that the connection to the main electricity supply complies with that reported in the water heater's instruction manual.
- Δ Check the electrical connections inside the control panel.
- Δ Check the D.H.W flow rate and temperature.
- Δ Check that the condensate drain system is working correctly, including any parts of the system outside the water heater such as condensate collection devices along the length of the flue and/or any acid neutralizing devices.
- Δ Check that the condensate flows freely and that there are no exhaust fumes present within the appliance.

**Warranty will not be offered if recommended maintenance is not followed.**

## 5.5 Accessing The Water Heater

All maintenance operations may require one or more of the water heater casing panels to be removed. The side panels can only be removed after the front panel has been removed. (see fig. 5.2)

### Front panel:

- Δ Remove the 4 fixing screws at the top and bottom of the front panel.
- Δ Grasp the lower part of the panel and pull it outwards and then upwards.

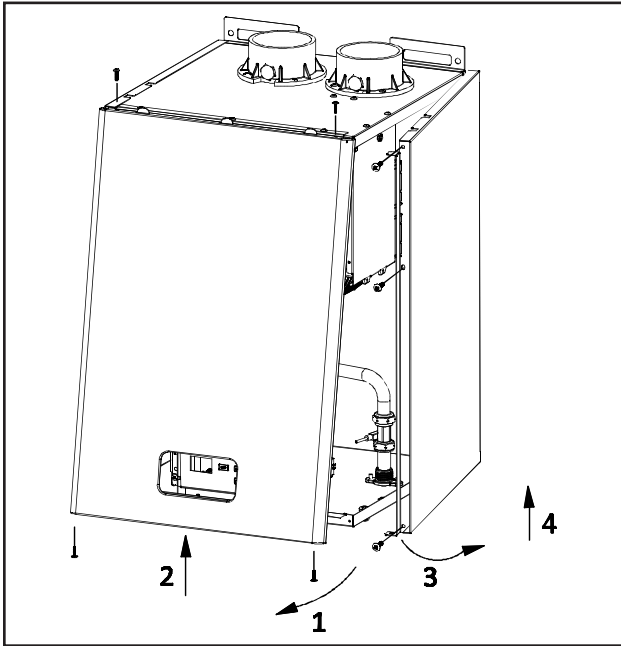

Figure 5.2 - Water heater access panels

### Left and right side panel:

- Δ Remove the fixing screws at the edge of the side panel.
- Δ Grasp the bottom of the panel, move it sideways and then upwards to remove it.

To access the electrical connections of the ignition control board and the main control board, proceed as follows:

### Ignition Control Board

- Δ Remove the front panel.
- Δ Remove the 2 fixing screws on the top front of the right panel
- Δ Remove the 2 fixing screws on the top of the shell.
- Δ The ignition board and bracket can now be removed by pulling it towards the front.

### Display Control Board

- Δ Remove the front panel.
- Δ Unscrew the four fixing screws and remove the cover.

### Draining the hot water system

If there is a danger of freezing, the hot water system should be drained. This can be done as follows:

- Δ Close the main water supply valve.
- Δ Open all the hot and cold water taps.
- Δ On completion, close all the previously opened taps.

## 5.6 Maintenance Operations

### 5.6.1 General Information

**⚠ Before carrying out any cleaning or part replacement operations, ALWAYS turn off the ELECTRICITY, WATER and GAS SUPPLY to the water heater.**

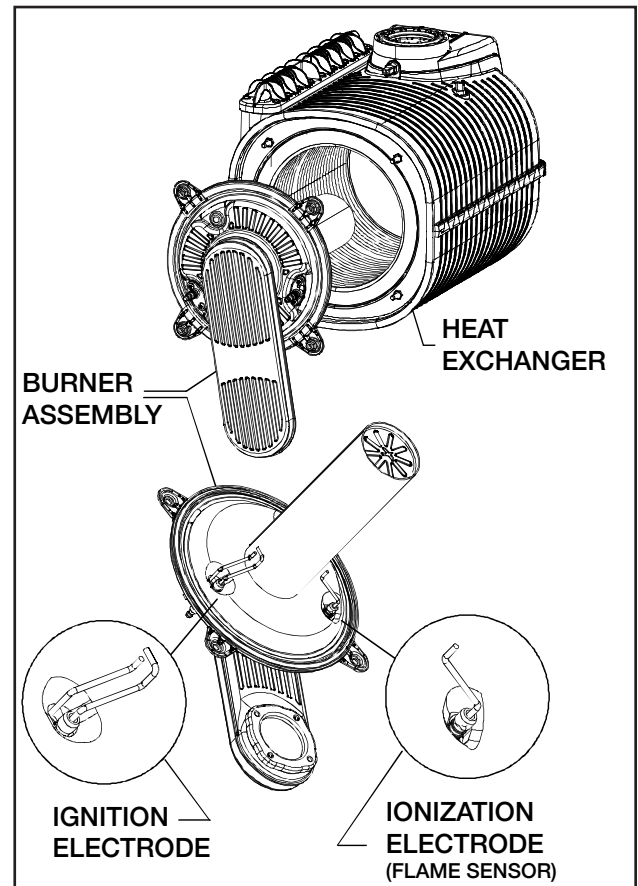

Figure 5.3 - Water heater burner assembly and heat exchanger

**⚠️ Glow Brand will not be held responsible for damage to any of the water heater's components caused by non-compliance with this instruction.**

Maintenance operations may require removal of the water heater casing.

1. Disconnect the electrical 120 VAC plug.
2. Un-plug the ignition electrode and flame detection wires from the ignition control unit.
3. Disconnect the joint and remove the pipe linking the gas valve to the injector unit (venturi).
4. Disconnect the joint and remove the gas feed pipe from the gas valve.
5. Unscrew the ring-nut at the bottom of the room-sealed chamber and remove the gas valve.
6. Unscrew the nuts securing the burner unit (consisting of a fan, manifold and burner) to the heat exchanger.
7. Remove the burner assembly, paying particular attention not to remove or damage the ceramic fiber.
8. Check that the burner is not affected by deposits, scaling or excessive oxidation. Check that all the holes in the burner are free.
9. Clean the electrodes carefully without altering their positions with respect to the burner.
10. Clean the burner cylinder using a non-metal brush and without damaging the ceramic fiber.
11. Check the integrity of the gasket on the cover of the burner.
12. Clean the heat exchanger using white vinegar or a suitable cleaner for stainless steel. Distribute the product on the spirals of the heat exchanger using a brush. Do not wet the ceramic fiber coating. Wait a few minutes then remove the deposits using a non-metal brush. Then remove the residues under running water.
13. Remove the gear clamp and condensate trap and clean by running under water.
14. Unscrew the joint to the condensate trap, remove the trap and wash under running water.
15. With the cleaning completed, re-assemble the components following the above procedure in reverse order.
16. Finally, check the water heater to make sure that all gas and exhaust joints are tight.

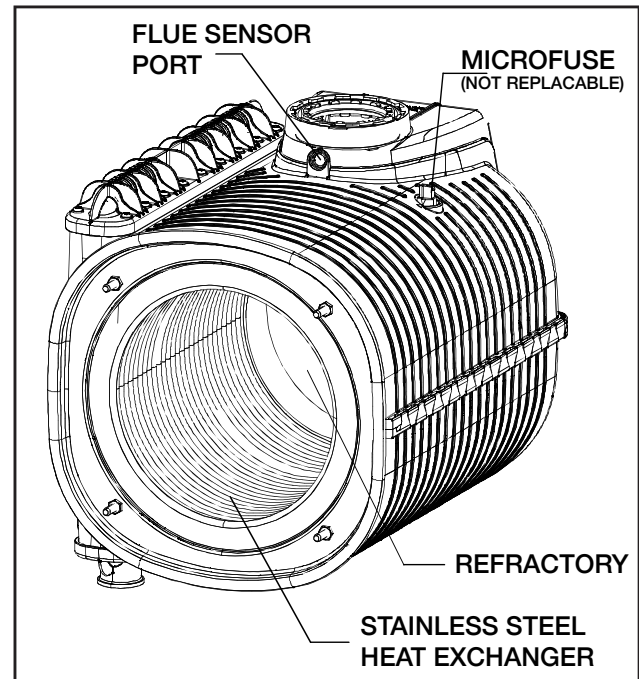

Figure 5.4 - Stainless Steel Heat Exchanger

### 5.6.2 Part Replacement:

Ignition and/or flame ionization electrodes:

1. Disconnect the voltage.
2. Un-Plug the electrode wires.
3. Remove the screws securing the electrodes in place.
4. Remove the electrodes and check that the gaskets are not damaged and replace if necessary.
5. Reconnect the wires and re-assemble the components following the above procedure in reverse order.
6. Switch on the power supply and restart the appliance.

**⚠️ If the water heater does not restart, check the positions of the electrodes (especially the ignition electrode). Make sure that original position and distances between the electrodes and the burner are respected to avoid a water heater malfunction).**

When inspecting the ignition electrode, a 4.5mm gap should be present between the grounding rod and the ignition electrode.

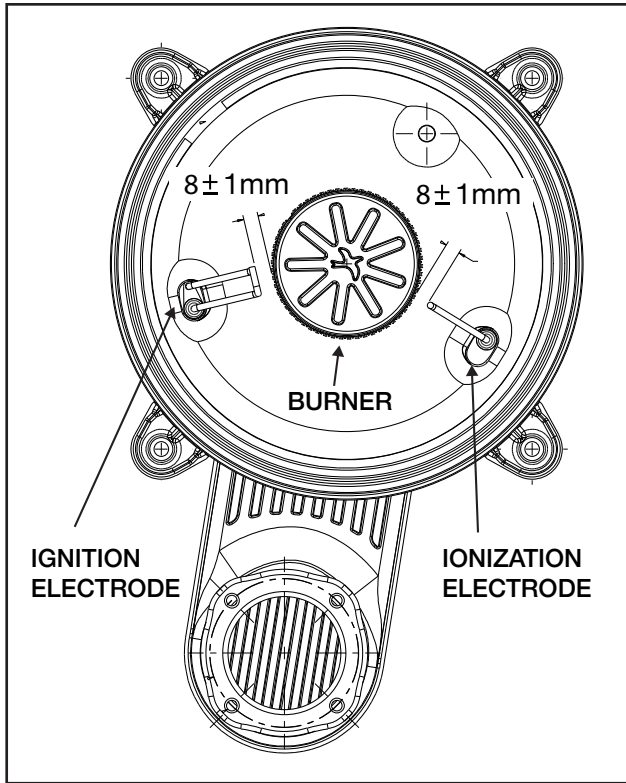

Figure 5.5 - Electrodes distance from the burner

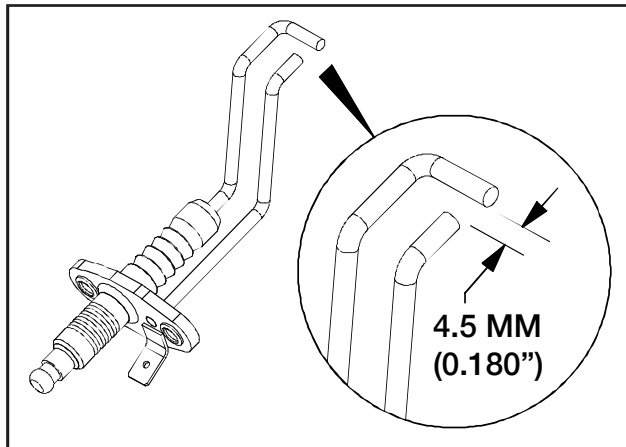

Figure 5.6 - Water heater electrode gap

### 5.6.3 High Limit Switch (Figure 5.7)

This high limit switch opens when the temperature in the loop exceeds 95°C. A manual reset of the unit is required.

- Δ Disconnect the voltage.
- Δ Un-plug the electrode wires.

- Δ Check for continuity between the two leads. If there is no continuity replace the switch.
- Δ Unscrew the fixing screws and remove the high limit switch.
- Δ Replace the high limit switch and re-assemble the components following the above procedure in reverse order.
- Δ Switch on the electricity, water and gas supplies and restart the appliance.

### 5.6.4 Water Sensors (see Figure 5.7)

- Δ Make certain the sensor is properly secured in place and making good contact with the water pipe.
- Δ Un-Plug the connecting wire.
- Δ Disconnect the wire leads of the domestic sensor. Set the multimeter to read Ohm's and apply the multimeter terminals to the sensor leads. You should have a value of "Nominal resistance at 25°C / 77°F – 10,000 Ohm". If the sensor does not provide the right data, as per the table, the sensor is out of calibration and needs to be replaced. (see section 7.10)
- Δ Replace the sensor and re-assemble the components following the above procedure in reverse order.
- Δ Switch on the electricity, water and gas supplies, open the shut-off valves and fill the central heating circuit. Then restart the appliance.

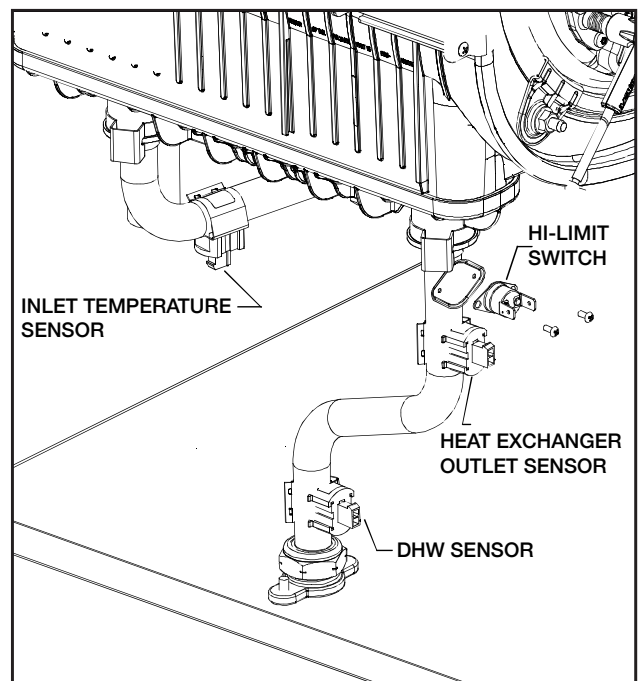

Figure 5.7 - Water heater sensors

## 5.7 Gas Supply Connections

**⚠ WARNING: Do not attempt to convert this water heater for use with a different type of gas other than the type shown on the rating plate. Doing so could result in death, personal injury, explosion or fire, product damage and or poor operating conditions or performance.**

- Δ All gas piping shall be in accordance with local utility company requirements and /or in the absence of local codes, use the latest edition of National Fuel Gas Code (NFGC), ANSI Z223.1. In Canada, use the latest edition of CSA B149.1, National Gas and Propane installation code.
- Δ Apply a thin coat of pipe compound to all the threaded male ends. Compound must be of the type resistant to the action of LP Gas.
- Δ To ensure proper water heater operation, the gas pipe and gas meter must be sized correctly.
- Δ If flexible connectors are used, the minimum inside diameter must be 3/4" or greater and the rated capacity if the connector must be equal to or greater than the BTU capacity of the water heater.
- Δ Do not use excessive force when tightening the pipe sections. Excessive force can damage the water heater, especially when Teflon pipe compound is used.
- Δ Switch on the electricity, water and gas supplies and check for any gas leaks using a soapy solution or leak detector spray.

### Gas valve (see fig. 5.8)

- Δ Use a 3 mm hex bit to remove the 4 bolts from the 1/2" NPT gas flange, on the underside of the unit. Careful not to damage the o-ring between the flange and the gas valve.
- Δ Remove the 2 torx screws (T25) that secure the gas valve to the venturi.
- Δ Pull down on the gas valve to separate it from the venture. Careful not to damage or lose the rubber coupling
- Δ Replace the gas valve and re-assemble the components following the above procedure in reverse order.
- Δ Check for gas leaks.

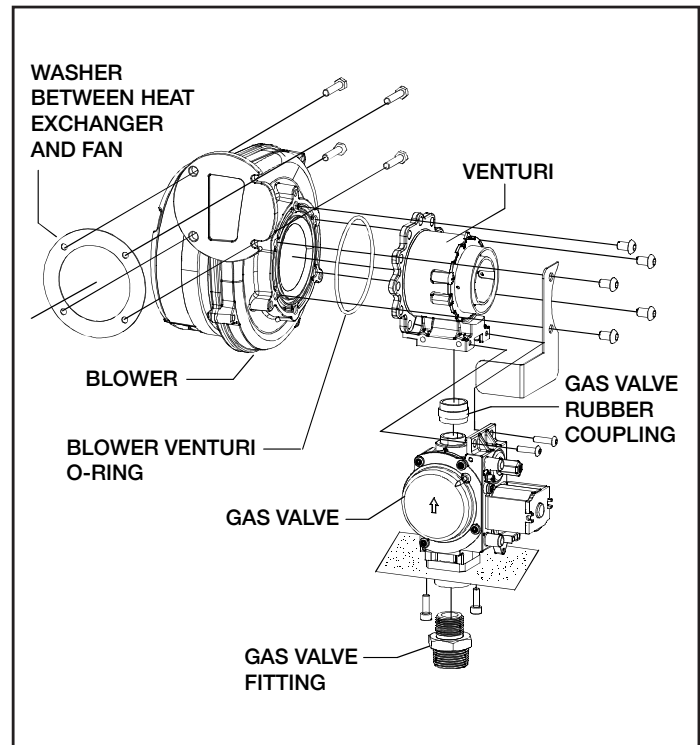

Figure 5.8 - Electric fan

### Electric fan (see fig. 5.8)

- Δ Remove and dismantle the entire burner assemble (see Section 5.5.1- 'General Information')
- Δ Use a 3 mm hex bit to remove the 4 bolts from the 1/2" NPT gas flange. Careful not to damage the o-ring between the flange and the gas valve.
- Δ Use an 8 mm wrench to unscrew the four nuts securing the electric fan to the gas manifold and then remove the electric fan, noting the position of the washer.
- Δ Unscrew the 4 torx screws from the venture and remove the electric fan, paying particular attention not to damage the blower venture o-ring.
- Δ Replace the electric fan and re-assemble the components following the above procedure in reverse order.
- Δ Switch on the electricity, water and gas supplies and check the integrity of the joint by measuring the CO<sub>2</sub> levels.

**6. Lock Out And Warnings**

DO NOT PRESS **RESET** WHEN THE FOLLOWING CODES APPEAR.  
 FOLLOW THE INSTRUCTIONS AS FOUND IN THE RESOLUTION COLUMN

Lockout Codes	Description	Resolution
A00	Internal software error	* Recycle power & press <b>RESET</b> * If lockout code still exists, replace ICB (Ignition Control Board) and display board
A01	Three unsuccessful attempts at ignition ignition attempts in a row	* Follow instruction given in flowchart: <b>A01</b> Ignition lockout
A02	Failure detected in gas valve circuit	* Verify electrical connections between gas valve and ICB * Recycle power and press <b>RESET</b> * If lockout code still exists, replace ICB and display board
A03	Failure detected in safety circuit within ICB	* Verify electrical connections between safety switches (Hi-limit, blocked flue switch), and all sensors and ICB * Recycle power and press <b>RESET</b> * If lockout code still exists, replace ICB and display board
A04	ICB has a <b>BLOCKING ERROR</b> for more than 20 hours.	* Press <b>RESET</b> , the <b>BLOCKING ERROR</b> will appear. * See <b>BLOCKING ERROR</b> on next page.
A05	Fan speed deviates for more than 60 seconds	* Verify electrical connections between fan and ICB
A06	Fan runs too slow for more than 60 seconds	* Recycle power and press <b>RESET</b>
A07	Fan runs too fast for more than 60 seconds	* If lockout code still exists, replace ICB and display board
A08	Internal software error	* Recycle power and press <b>RESET</b>
A11	Internal software error	* If lockout code still exists, replace ICB and display board
A12	Internal software error	
A15	Hi-Limit switch or micro fuse is open	* Follow instruction given in flowchart: <b>A15</b> Hi-limit switch open or microfuse open
A16	Flue temperature exceeded the maximum flue temperature (65°C/150°F)	* Follow instruction given in flowchart: <b>A16</b> Flue gas temperature exceeds limit (65°C/150°F)
A17	Internal software error	* Recycle power and press <b>RESET</b>
A18	Internal software error	* If lockout code still exists, replace ICB and display board
A19	Internal software error	
A20	Flame still present 10 seconds once gas valve is de-energized	* Power OFF the unit and clean ionization electrode * Recycle power and press <b>RESET</b> * Allow the burner to operate at high fire for 1 minute if <b>A20</b> still appears replace the ICB * Recycle power and press <b>RESET</b>
A21	Flame is detected prior to ignition	* Power OFF the unit and clean ionization electrode * Recycle power and press <b>RESET</b> * Allow the burner to operate at high fire for 1 minute if <b>A20</b> still appears replace the ICB * Recycle power and press <b>RESET</b>
A22	Flame is lost 3 times during one demand	* Check intake & exhaust vent for obstructions and clear if any * Check gas pressure at line pressure test port of gas valve. If pressure fluctuates out of specified range, contact gas supplier. * Check main power supply voltage, if voltage fluctuates out of specified range, contact qualified electrician * Power off the unit, clean ionization electrode and secure its connection to the ICB * Check for blockage in condensate trap and heat exchanger. If blockage exists, clean trap and or heat exchanger * Recycle power and press <b>RESET</b>



Lockout Codes	Description	Resolution
A24	Blocked flue switch is open	* Follow instruction given in flowchart: <b>A24</b> Block flue switch open
A29	Internal software error	* Recycle power and press <b>RESET</b> * If lockout code still exists, replace ICB and display board
A30	Internal software error	* Recycle power and press <b>RESET</b> * If lockout code still exists, replace ICB and display board

Press **RESET** to restore unit to normal operating mode

Blocking Errors	Description	Resolution
E100	Internal software error	* Recycle power and press <b>RESET</b> * If <b>BLOCKING ERROR</b> still exists, replace ICB and display board
E101		
E102		
E103		
E104		
E106		
E107		
E108		
E109		
E110		
E111		
E112		
E113		
E114	Flame is detected and not present	* Power OFF the unit and clean ionization electrode * Recycle power and press <b>RESET</b> * Allow the burner to operate at high fire for 1 minute if <b>E114</b> still appears replace the ICB * Recycle power and press <b>RESET</b>
E119	DCW inlet sensor failure	* Follow instruction in flowchart: <b>E119</b> DCW inlet sensor failure
E120	Heat exchanger outlet sensor failure	* Follow instruction in flowchart: <b>E120</b> heat exchange outlet sensor failure
E122	DHW outlet sensor failure	* Follow instruction in flowchart: <b>E122</b> DHW outlet sensor failure
E123	Flue sensor failure	* Follow instruction in flowchart: <b>E123</b> flue sensor failure
E126	DCW sensor shorted	* Recycle the power * If <b>E126</b> BLOCKING ERROR still exists, replace DCW inlet sensor
E127	Heat exchanger outlet sensor shorted	* Recycle the power * If <b>E127</b> BLOCKING ERROR still exists, replace heat exchanger outlet sensor
E129	DHW sensor shorted	* Recycle the power * If <b>E129</b> BLOCKING ERROR still exists, replace DHW outlet sensor
E130	Flue sensor shorted	* Recycle the power * If <b>E130</b> BLOCKING ERROR still exists, replace flue sensor
E134	Too many RESETs in a short time period	* Power OFF unit, wait 5 minutes, Power ON unit * If <b>E134</b> BLOCKING ERROR still exists, replace ICB and display board
E135	Incorrect polarity	* Power OFF the unit * Check and reverse the polarity at the receptacle

## 7. Troubleshooting

### 7.1 Ignition Lock-Out

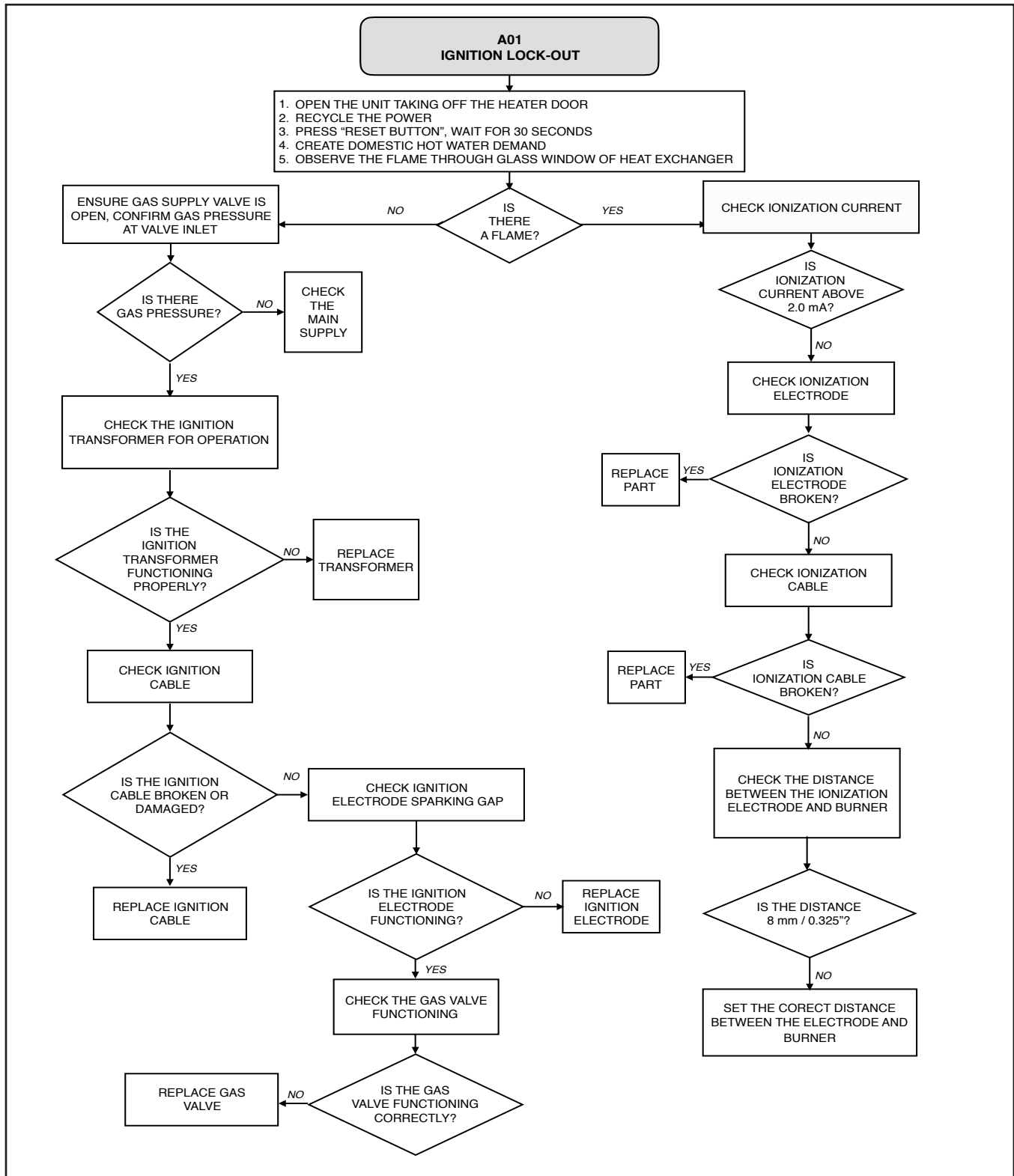

7.2 High Limit Or Microfuse Open

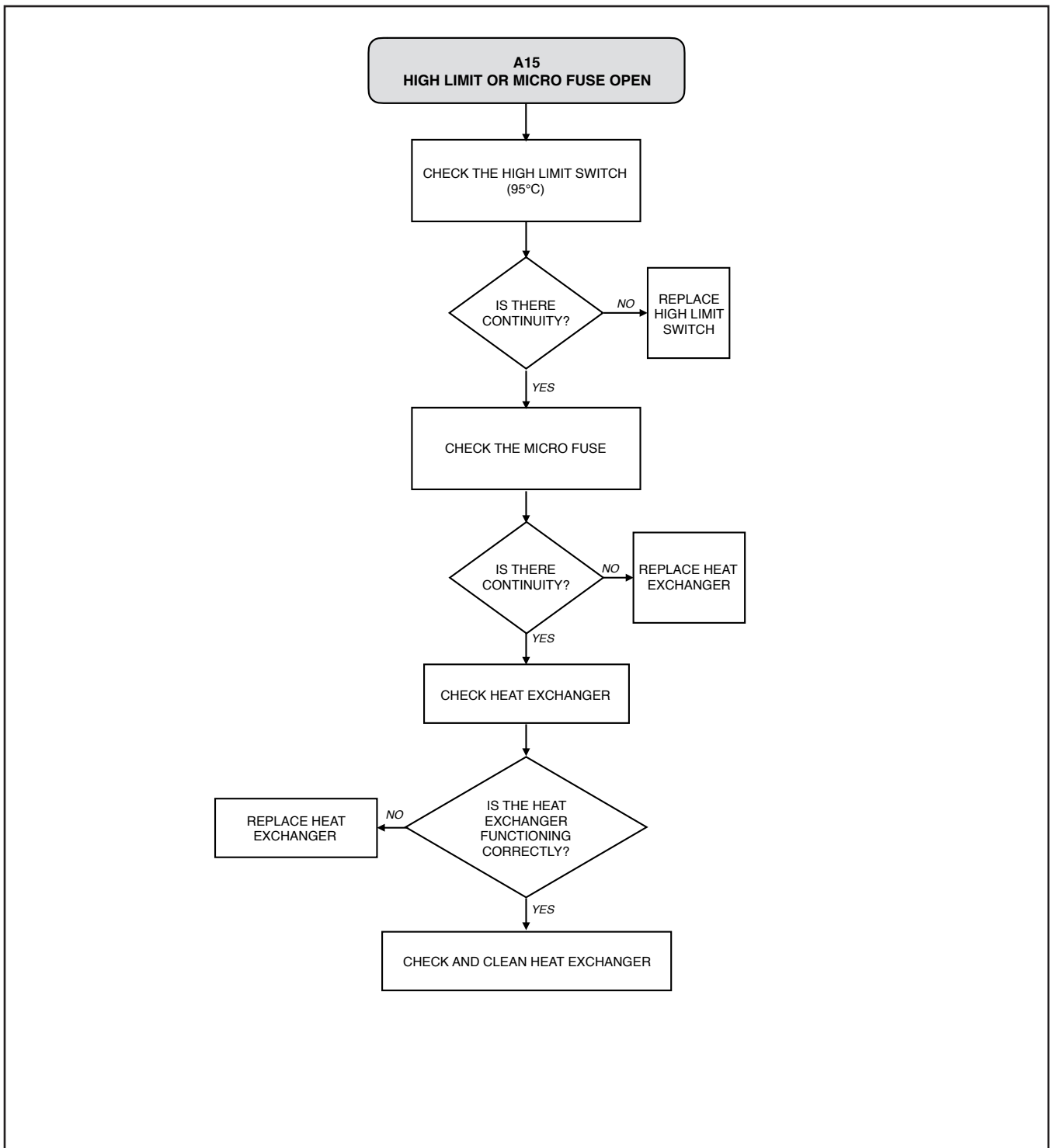

7.3 Flue Gas Temperature Exceeds The Limit

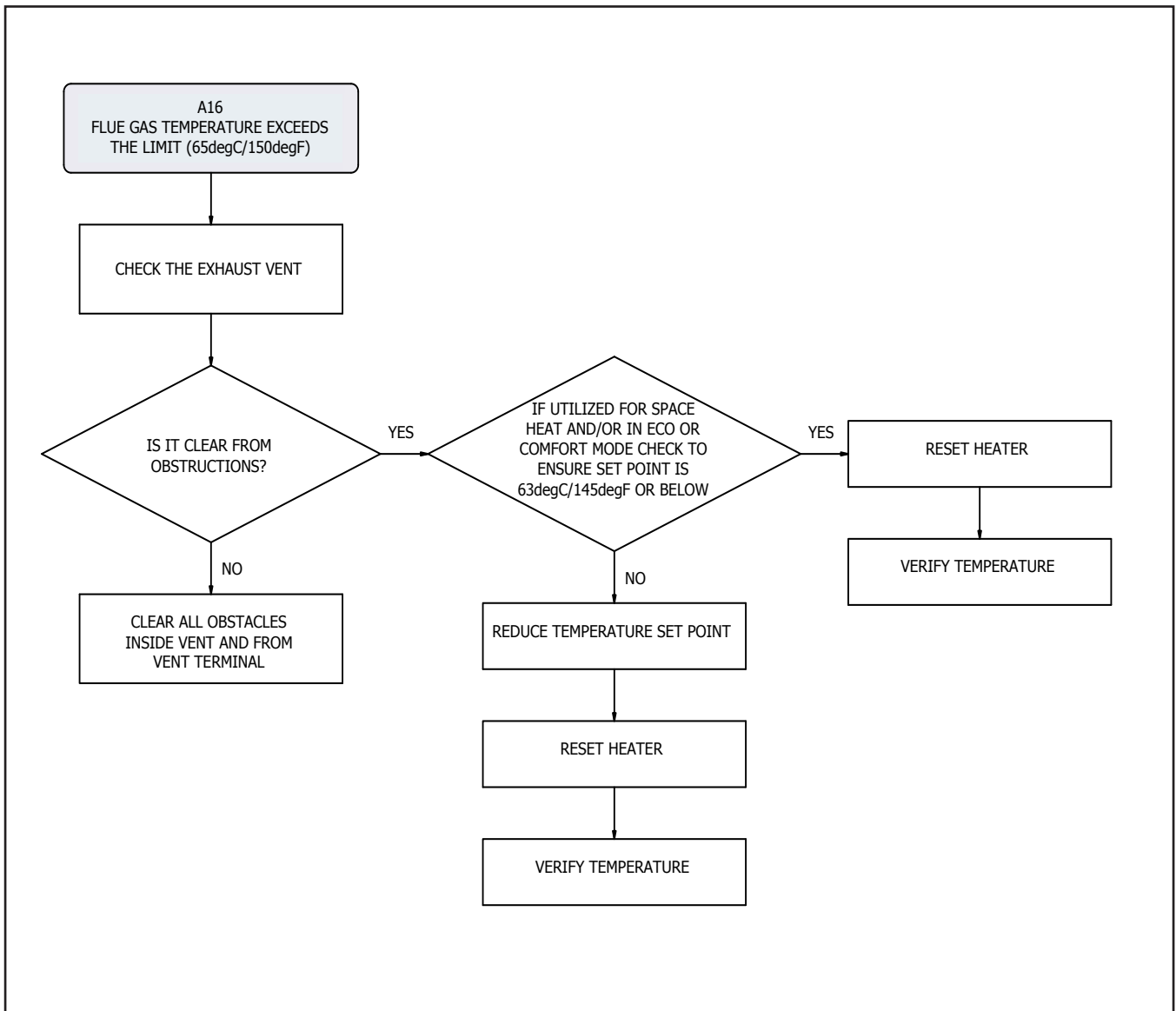

 **DHW Set point cannot be set higher than 145°F/63°C for space heating applications.**

7.4 Block Flue Switch Open

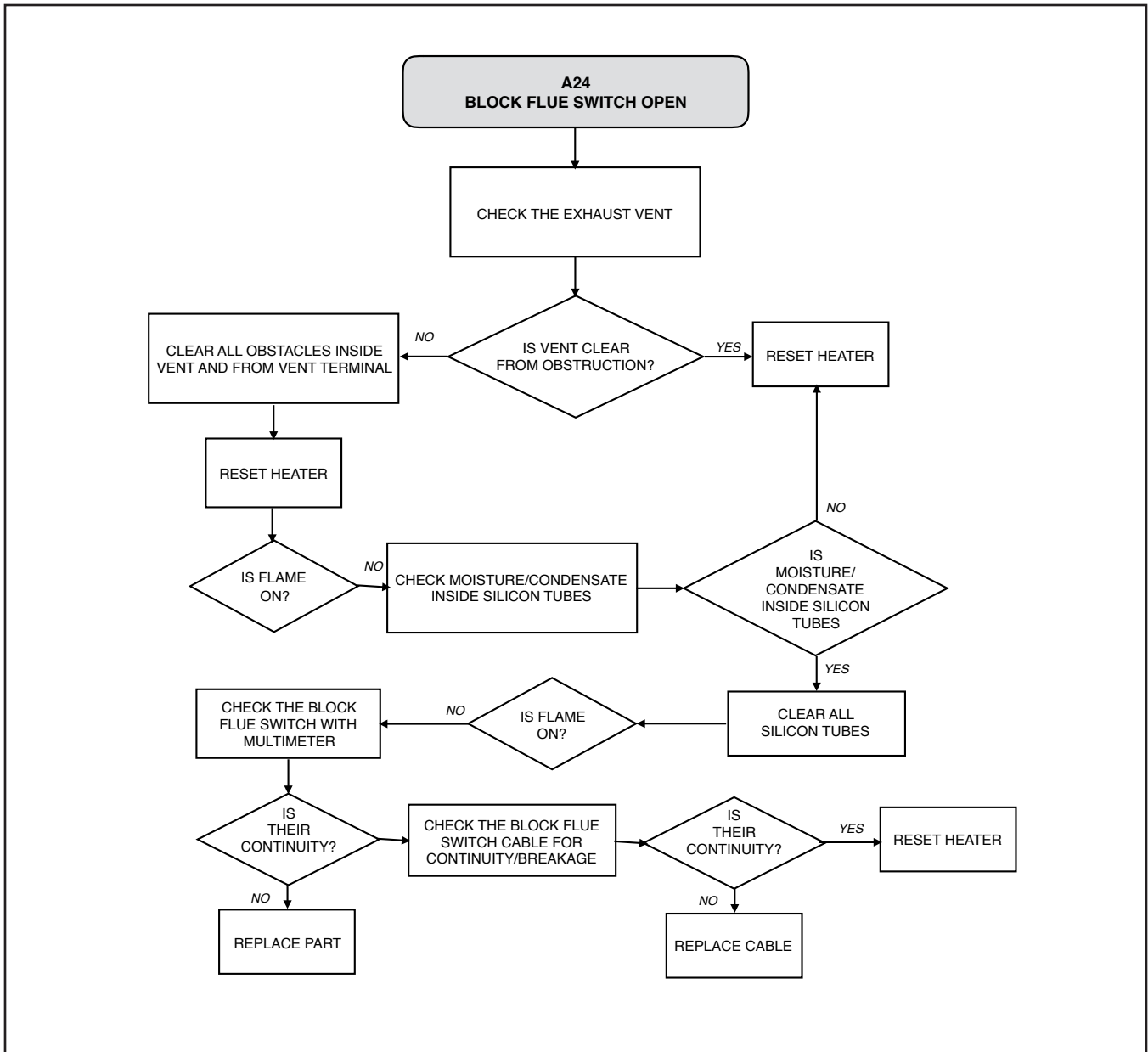

7.5 DCW Inlet Sensor Failure

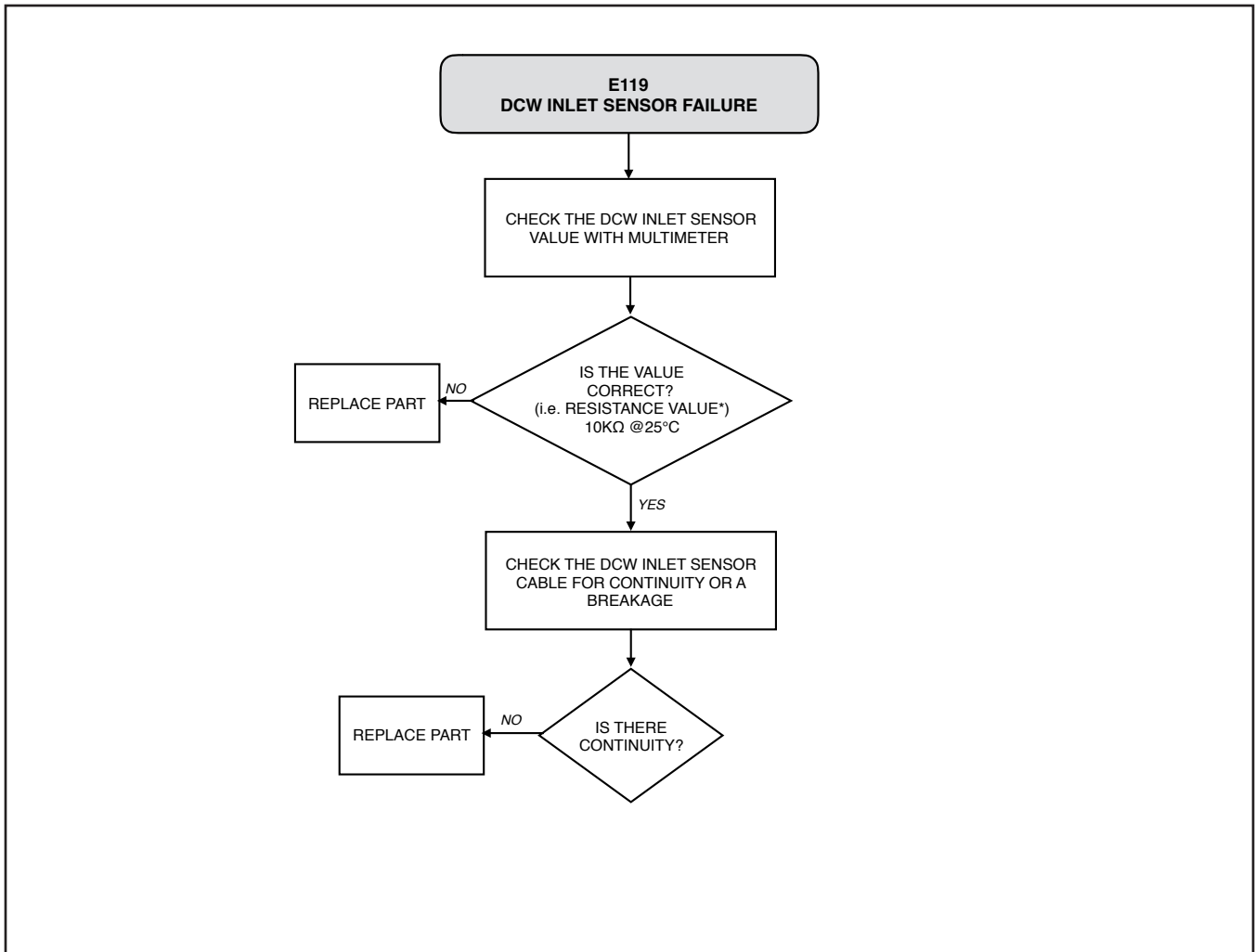

7.6 Heat Exchanger Outlet Sensor Open

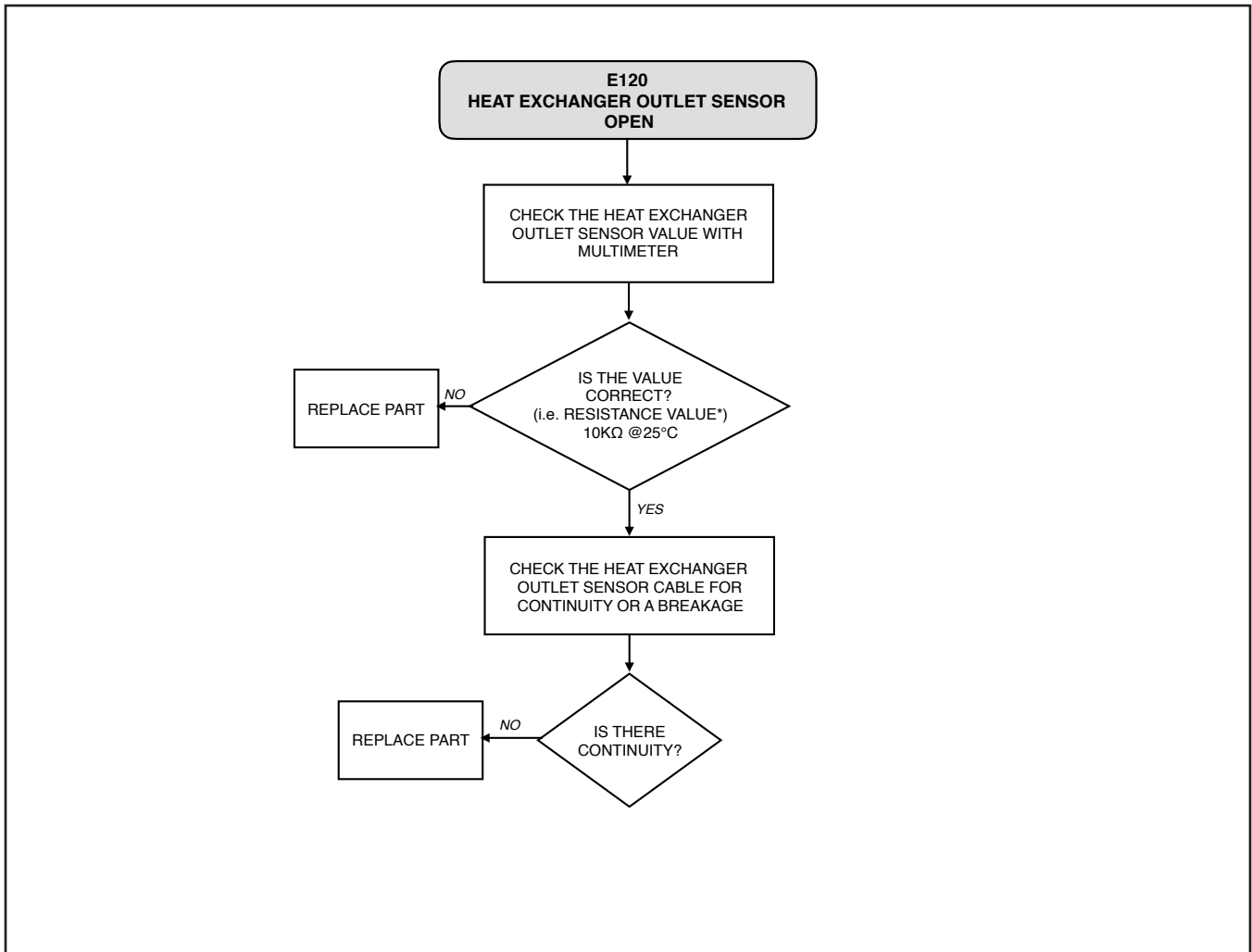

7.7 DHW Sensor Open

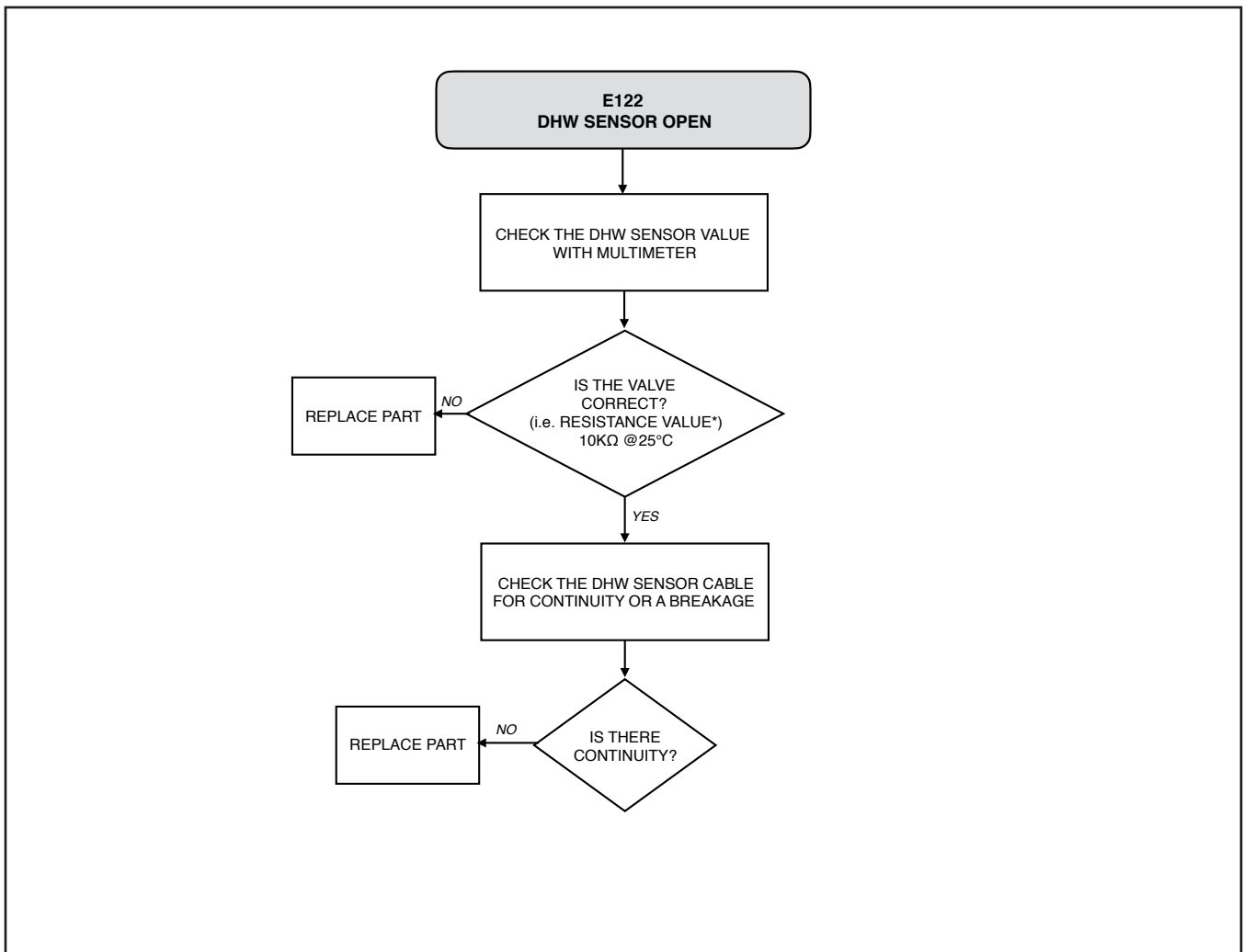



7.8 Flue Sensor Open

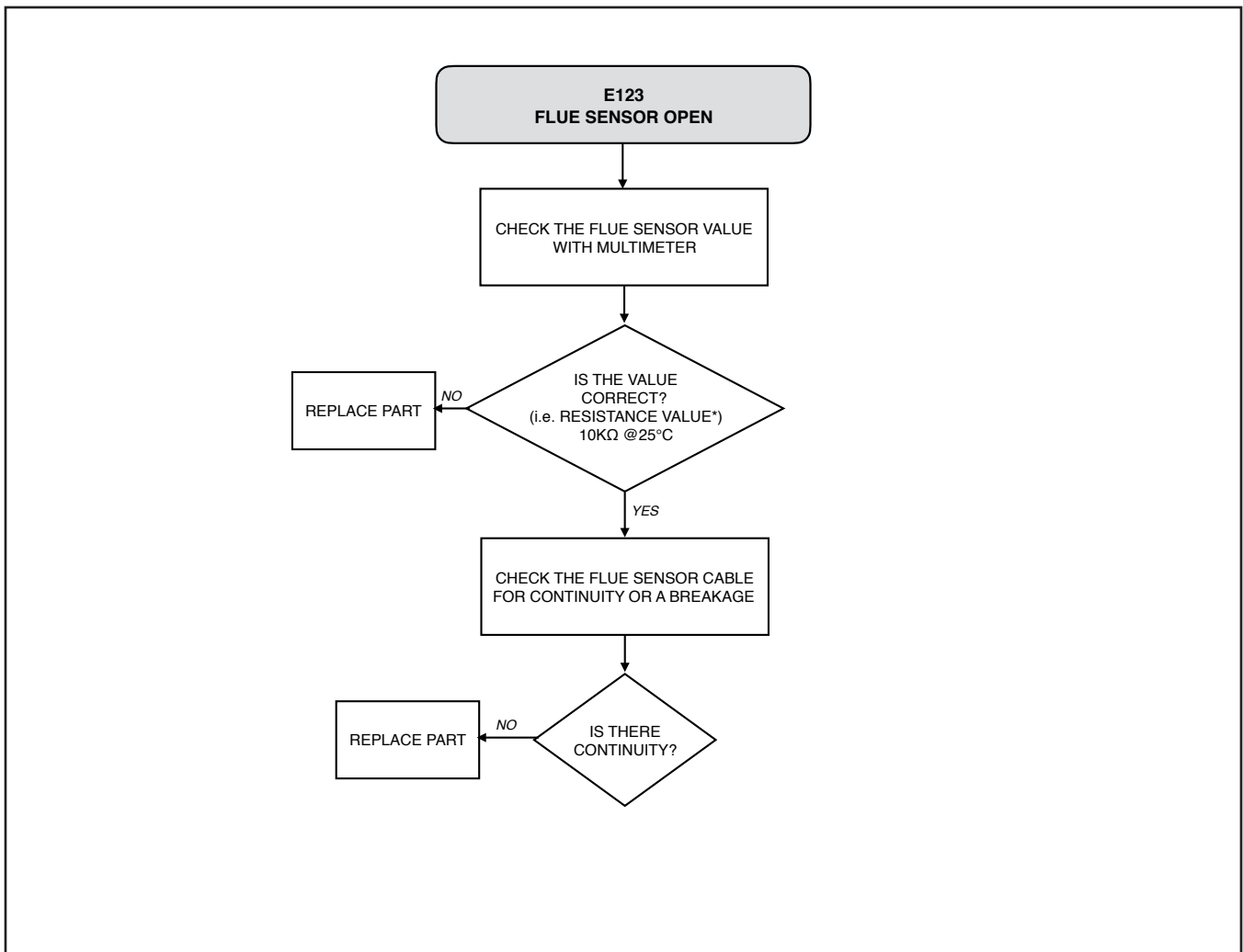

7.9 No Hot Water

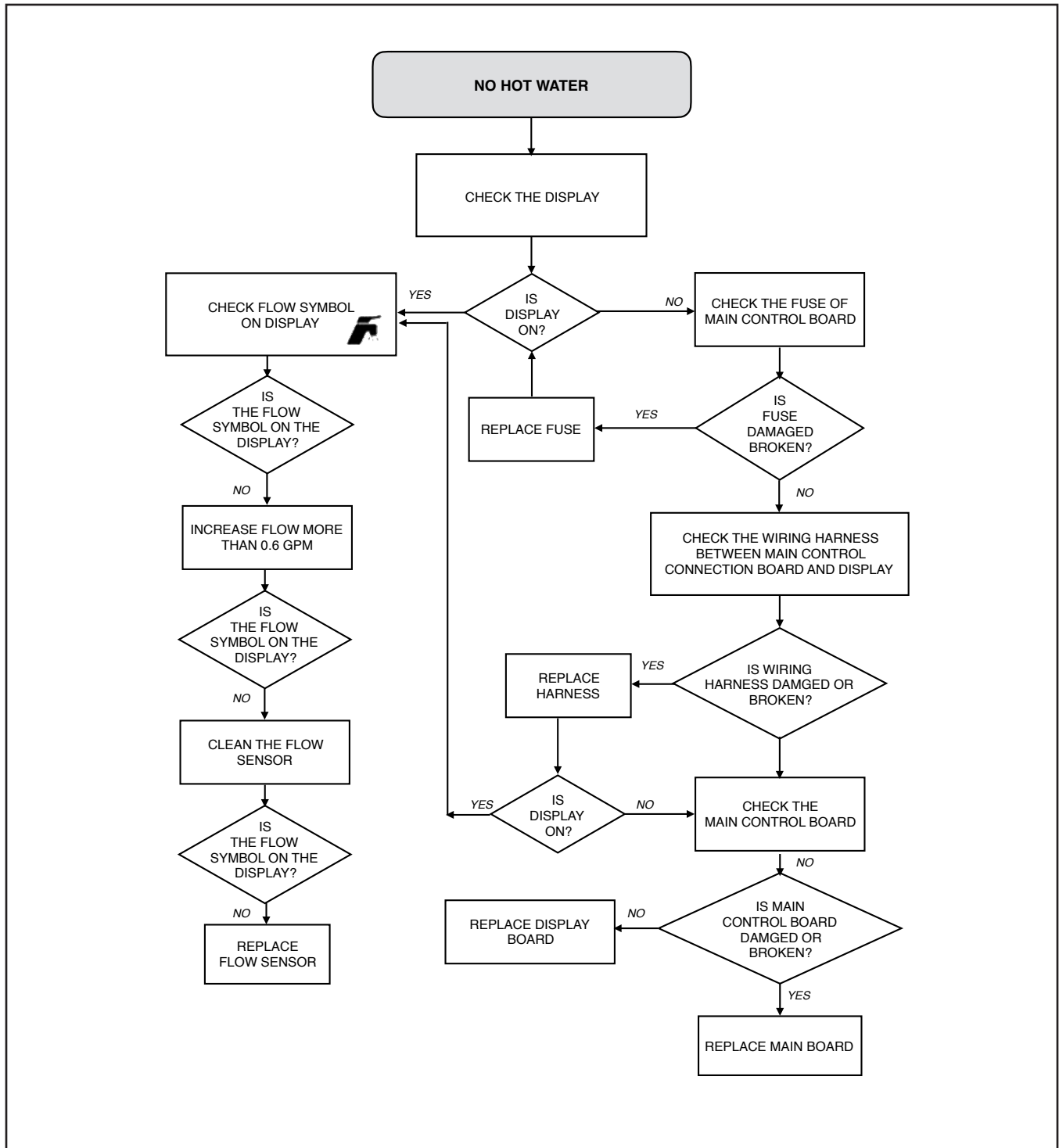

7.10 Resistance Value Versus Temperature

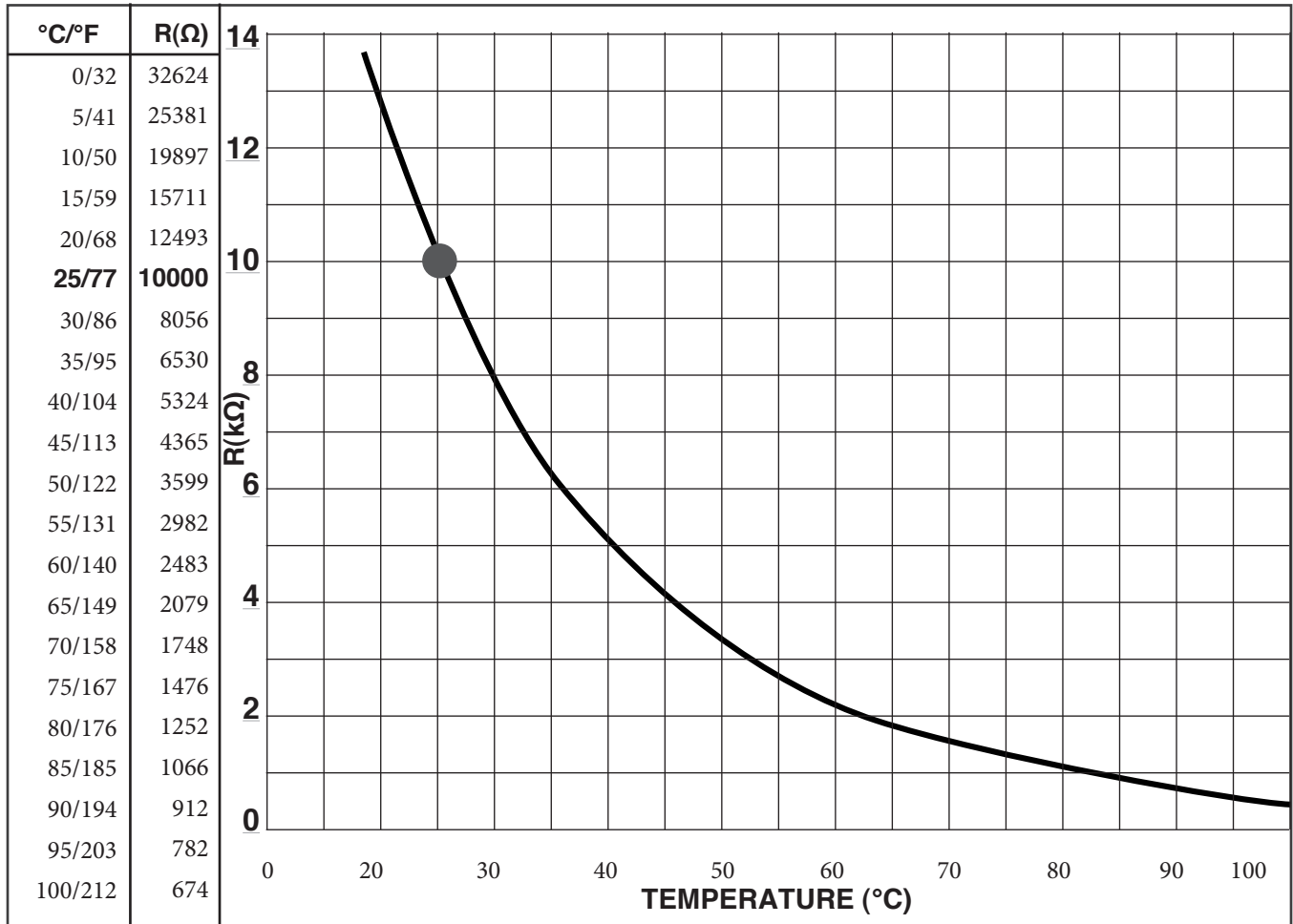

Table 8.1

8. Parts List - Available From Glow Brand

8.1 Cabinet And Interior

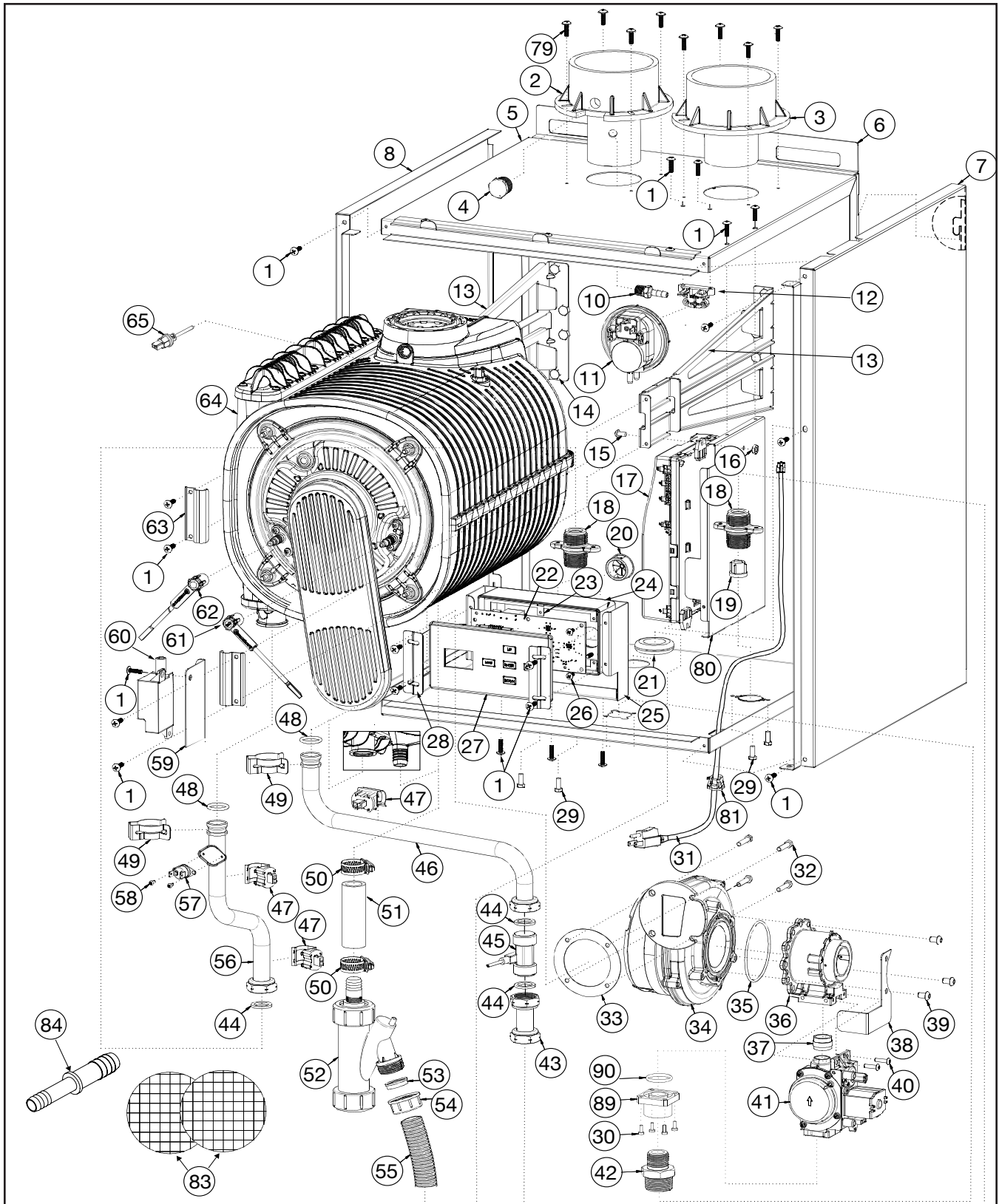

Figure 8.1 Cabinet and interior parts

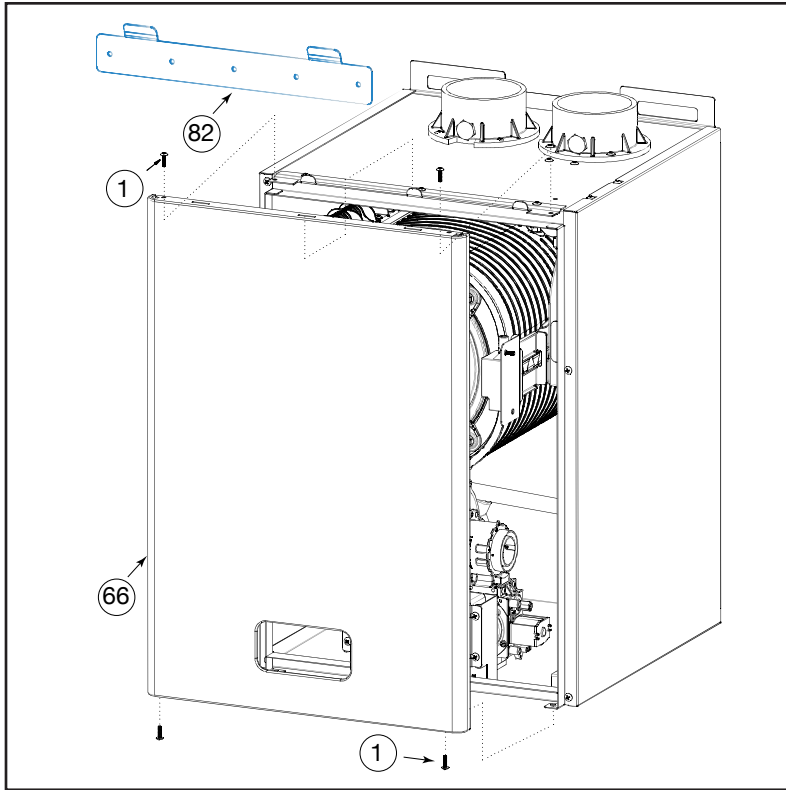

Figure 8.2 Door Mounting

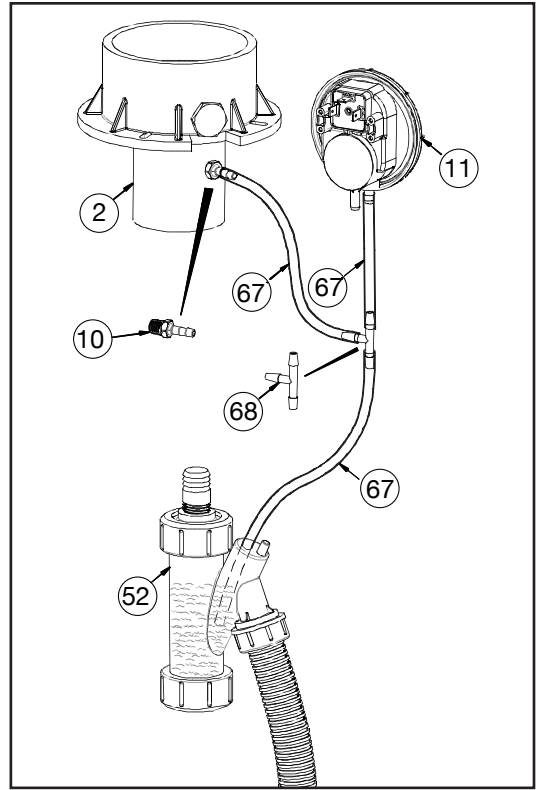

Figure 8.3 Block Flue Switch Loop

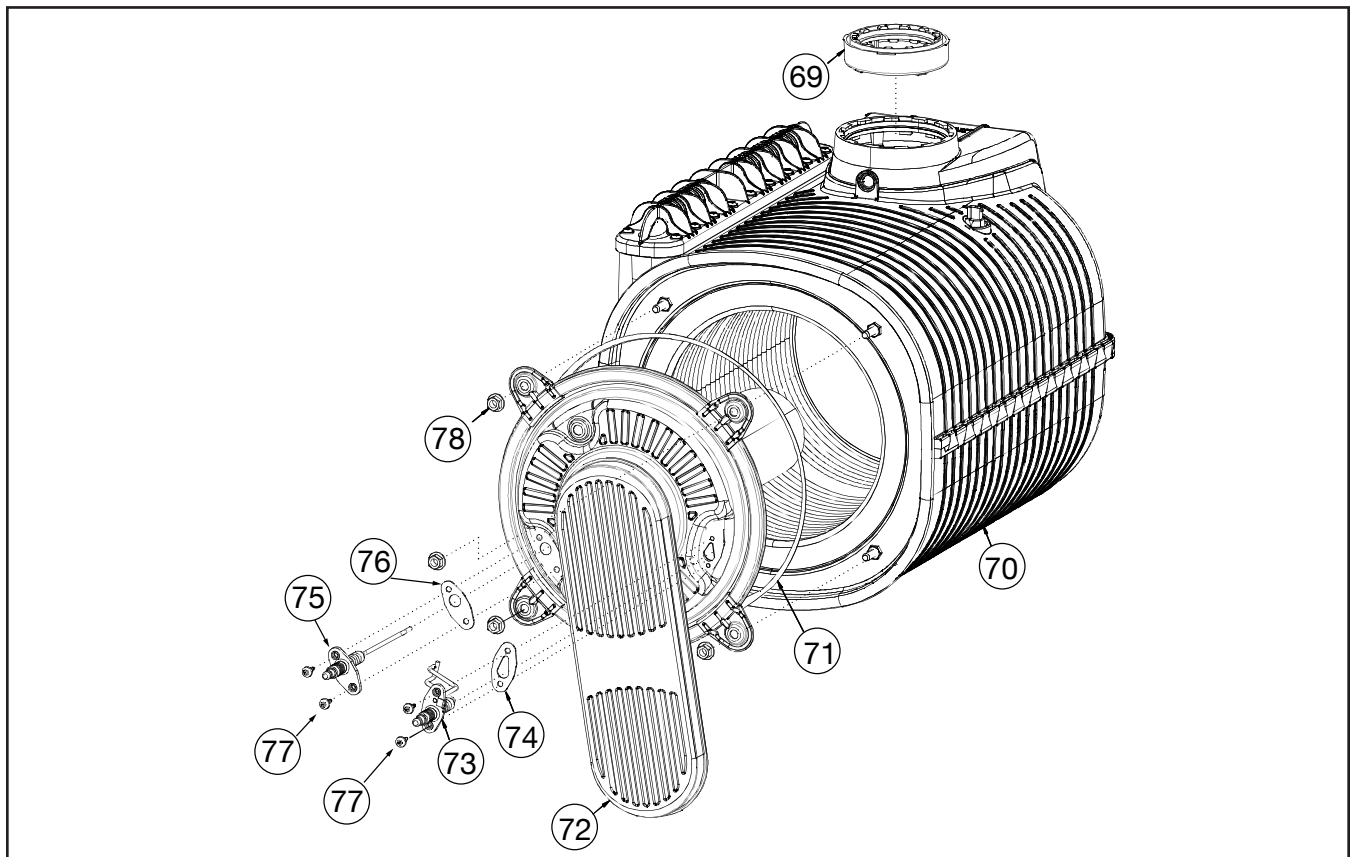

Figure 8.4 Heat Exchange Parts

**8.2 Water Connections**

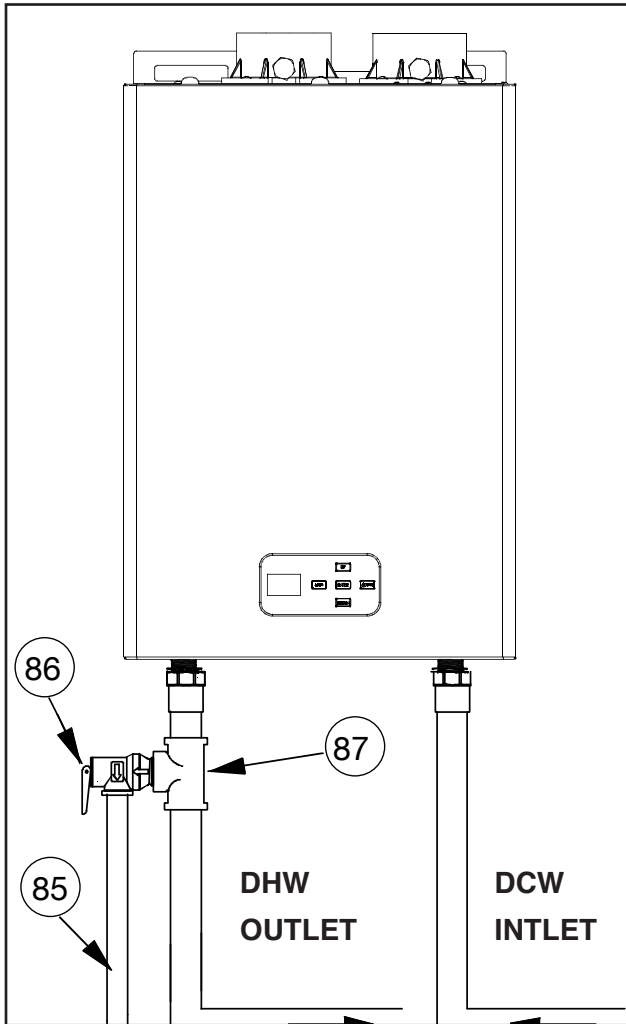

Figure 8.5 - Water Heater Connections

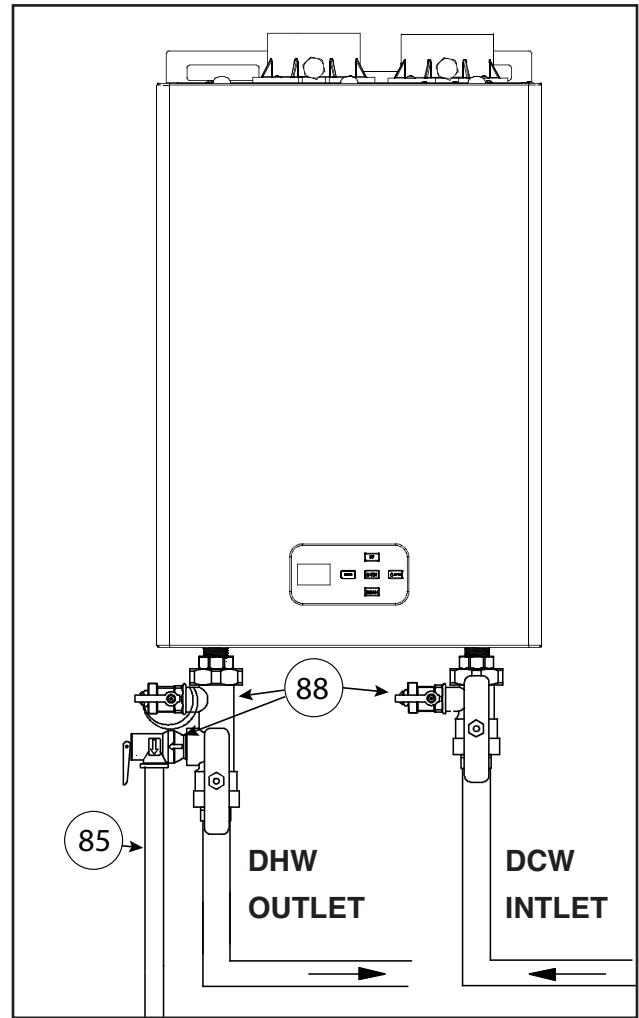

Figure 8.6 - Water Heater with Optional Service Kit

Item#	Part#	Description
85	19000005-A	TUBE FOR SAFETY RELIEF VALVE (DRIP TUBE) (NOT SUPPLIED WITH UNIT)
86	GLO-180-43	PRESSURE RELIEF VALVE
87	GLO-180-23	3/4" BRASS TEE
88	GLO-180-44	TANKLESS WATER HEATER SERVICE VALVE KIT (NOT SUPPLIED WITH UNIT)

Table 8.2

## Parts List For Figures 8.1, 8.2, 8.3, 8.4, 8.5 & 8.6

Item#	Part#	Description
1	GLO-180-103	8-32 X 1/2 STEEL PAN PHILLIP T/SCREWS TYPE F
2	GLO-02	EXHAUST FLUE ADAPTER (LONG)
3	GLO-01	COMBUSTION AIR INLET ADAPTER (SHORT)
4	GLO-02-PLUG	PVC VENT PLUG
5	GLO-180-S-01	TOP, BACK & BOTTOM UNI-SHELL
6	GLO-180-S-08	REAR SUPPORT MOUNTING BRACKET
7	GLO-180-S-15	PAINTED - TANKLESS RIGHT PANEL
8	GLO-180-S-16	PAINTED - TANKLESS LEFT PANEL
9	GLO-180-S-09	DOOR, SUPPORT BRACKET
10	GLO-51	HOSE BARB (3/16" NYLON) (1/180 unit)
11	GLO-180-150	BLOCKED FLUE SWITCH (3.28 Mbar)
12	GLO-180-21	BLOCKED FLUE SWITCH MOUNTING BRACKET
13	GLO-59	HEAT EXCHANGER SUPPORT BRACKETS
14	GLO-180-104	10-24 X 1/2 HWH THREAD CUTTING (SCREWS)
15	GLO-180-107	10 - 32 X 1/2" Pan Sq/SI Ms Zp, SCREWS
16	GLO-180-108	10 - 32 K-LOCK NUT
17	GLO-552	IGNITION CONTROL BOARD (ICB)
18	GLO-180-50	3/4" NPT BRASS WATER INLET/OUTLET FITTINGS
19	GLO-180-250	WATER INLET SCREEN (WHITE)
20	GLO-53	7/8" DIAMETER PVC GROMMET
21	GRO-001	CONDENSATE HOSE GROMMET
22	GLO-551	DISPLAY BOARD
23	GLO-180-S-03	DISPLAY BOARD MOUNTING BRACKET
24	GLO-180-51	DISPLAY BOARD REAR ENCLOSURE
25	GLO-180-S-10	METAL ENCLOSURE SUPPORT
26	GLO-180-101	6 X 3/8" SCREWS
27	GLO-180-52	DISPLAY BOARD COVER PLATE
28	GLO-180-S-18	ENCLOSURE LOCKING TABS
29	GLO-180-105	10-32 X 1/2" SCREWS
30	GLO-563	GAS VALVE ADAPTER SCREWS M4 X 12 SOCKETCAP
31	FM-180-HRN-006	POWER SUPPLY CABLE
32	GLO-180-106	M5 X 12 DIN933 -8.8 HEX SCREW
33	GLO-50	FAN/BURNER GASKET
34	GLO-543	FAN
35	GLO-544	FAN / VENTURI O-RING

## Parts List For Figures 8.1, 8.2, 8.3,8.4, 8.5 & 8.6 (continued)

Item#	Part#	Description
36	GLO-545	VENTURI (NG)
36	GLO-546	VENTURI (LP)
37	GLO-547	GAS VALVE RUBBER COUPLING
38	GLO-180-S-11	DISPLAY ENCLOSURE SUPPORT BRACKET
39	GLO-180-109	VENTURI MOUNTING HEX SCREW
40	GLO-180-110	GAS VALVE MOUNTING SCREW
41	GLO-541	GAS VALVE (NG)
41	GLO-542	GAS VALVE (LPG)
42	GLO-180-40	1/2" X 3/4" BRASS REDUCER, GAS
43	FLM-005	3/4" INLET WATER STUB - WITH UNIONS
44	GLO-40	3/4" RUBBER WASHER
45	GLO-52	DCW FLOW SENSOR
46	FLM-004	INLET WATER PIPE - WITH 3/4" BRASS UNION
47	GLO-41	WATER TEMPERATURE SENSOR
48	GLO-46	O-RING (180)
49	GLO-180-45	SS CLIP FOR COPPER PIPE
50	GLO-180-41	GEAR CLAMP
51	GLO-180-111	HEAT EXCHANGER CONDENSATE TUBE
52	GLO-48	CONDENSING TRAP
53	GLO-180-112	SEAL, CONDENSATE TRAP
54	GLO-180-113	PLASTIC UNION NUT, CONDENSATE TRAP
55	GLO-47	CONDENSATE DRAIN
56	FLM-003	OUTLET WATER TUBE - WITH 3/4" BRASS UNION
57	EKA-323-39	DHW HIGH TEMPERATURE LIMIT SWITCH (95°C)
58	GLO-180-100	HIGH LIMIT SWITCH SCREW
59	GLO-180-S-12	IGNITION TRANSFORMER MOUNTING BRACKET
60	GLO-49	IGNITION TRANSFORMER
61	GLO-43	IGNITION ELECTRODE CABLE (180)
62	GLO-44	LEAD, IONIZATION ELECTRODE CABLE (180)
63	GLO-60	HEAT EXCHANGER SUPPORT CLAMP
64	GLO-58	HEAT EXCHANGER ASSEMBLY ((INCLUDES BURNER/ELECTRODE)
65	GLO-42	HEAT EXCHANGER FLUE TEMPERATURE SENSOR
66	GLO-180-S-17	PAINTED - TANKLESS DOOR
67	GLO-180-22	SILCONE CONDENSATE HOSE 36"
68	GLO-65	BLACK POLYPRO BARBED TEE, 3/16"



**Parts List For Figures 8.1, 8.2, 8.3, 8.4, 8.5 & 8.6 (continued)**

Item#	Part#	Description
69	GLO-62	FLUE OUTLET ADAPTER (60mm)
70	GLO-581	STAINLESS STEEL HEAT EXCHANGER
71	GLO-585	GASKET BURNER PLATE
72	GLO-584	BURNER AND PLATE
73	GLO-582	IGNITION ELECTRODE
74	GLO-586	GASKET, IGNITION ELECTRODE
75	GLO-583	IONIZATION ELECTRODE
76	GLO-587	GASKET, IONIZATION ELECTRODE
77	GLO-588	ELECTRODE MOUNTING SCREW
78	GLO-589	BURNER MOUNTING NUTS
79	GLO-180-114	VENT ADAPTER SCREWS
80	GLO-180-S-02	ICB MOUNTING BRACKET
81	GLO-180-42	STRAIN RELIEF
82	GLO-180-S-13	WALL MOUNT SUPPORT BRACKET
83	SCREEN	GALVANIZED BIRD SCREEN
84	GLO-180-77	1/2"-3/4" PLASTIC CONDENSATE TUBE FITTING
85	19000005-A	TUBE FOR SAFETY RELIEF VALVE (DRIP TUBE) (NOT SUPPLIED WITH UNIT)
86	GLO-180-43	PRESSURE RELIEF VALVE
87	GLO-180-23	3/4" BRASS TEE
88	GLO-180-44	TANKLESS WATER HEATER SERVICE VALVE KIT (NOT SUPPLIED WITH UNIT)
89	GLO-562	1/2" NPT GAS VALVE BRASS ADAPTER
90	GLO-561	O-RING, GAS VALVE
91	GLO-563	GAS VALVE ADAPTER SCREW

Optional Accessories	
Part#	Description
140-103	RECIRCULATION PUMP UPS15-55SUC/TLC W/ TIMER
140-003	RECIRCULATION PUMP UPS15-58
96806141	1/2" SWEAT CONNECT KIT W/ CHECK VALVE (for use with 140-003)
96806143	3/4" SWEAT CONNECT KIT W/ CHECK VALVE for use with 140-003)
GLO-180-80	HIGH TEMPERATURE AQUASTAT (105°F / 10°F Diff)
GLO-103-01	BYPASS VALVE
GLO-103-02	1/2" x 1/2" FLEX BRAID HOSE KIT (2PCS)
GLO-103-03	3/8" x 1/2" FLEX BRADE HOSE KIT (2PCS)
529913	1/2" SWEAT CONNECT KIT W/ CHECK VALVE (for use with 140-103)
529911	3/4" SWEAT CONNECT KIT W/ CHECK VALVE (for use with 140-103)

**Recirculating Pump and Accessories**



Figure 8.7 Recirculating Pumps and Fittings

## 8.3 Electrical Connections

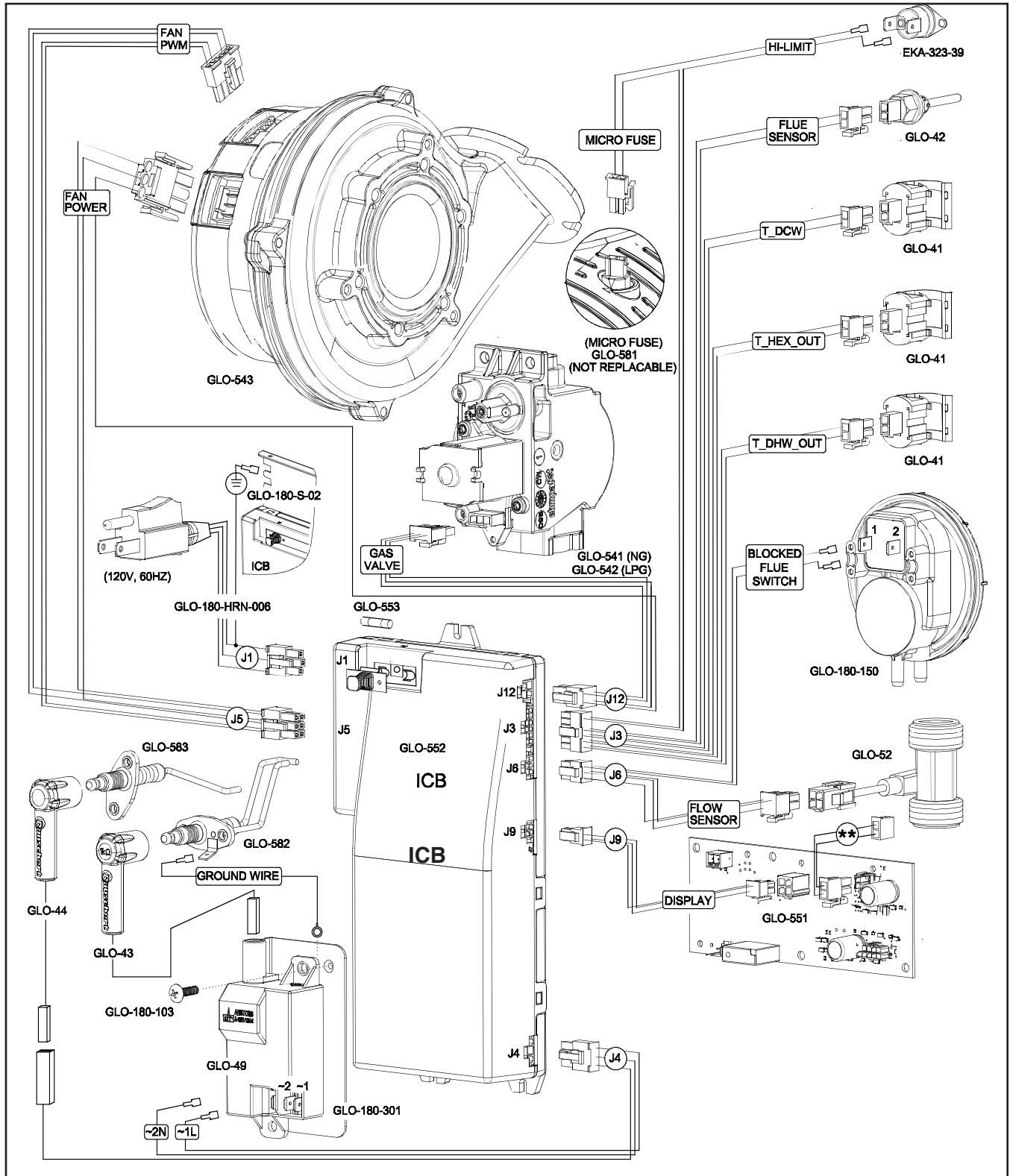

Figure 8.8 Wiring Diagram

Parts List For Electrical Connections - Figure 8.8

Connector	Harness #	Description
J1	FM-180-HRN-006	POWER SUPPLY CABLE WITH PLUG (120V,60HZ)
J3	FM-180-HRN-002	SAFETY, FLUE AND WATER TEMPERATURE WIRING HARNESS
J4	FM-180-HRN-005	IGNITION TRANSFORMER AND IONIZATION ELECTRODE HARNESS
J5,J12	FM-180-HRN-001	FAN, GAS VALVE WIRING HARNESS
J6	FM-180-HRN-004	FLOW SENSOR AND BLOCKED FLUE SWITCH HARNESS
J9	FM-180-HRN-007	DISPLAY BOARD WIRING HARNESS
GROUNDWIRE	FM-180-HRN-003	IGNITION ELECTRODE GROUND WIRE

Part #	Description
EKA-323-29	DHW HIGH TEMP LIMIT SWITCH
GLO-42	HEAT EXCHANGER FLUE TEMP SENSOR
GLO-41	DCW TEMP SENSOR
GLO-41	HEAT EXCHANGER OUTLET WATER TEMP SENSOR
GLO-41	DHW TEMP SENSOR
GLO-180-150	BLOCKED FLUE SWITCH (N/C)
GLO-52	DCW FLOW SENSOR
GLO-551	DISPLAY BOARD
GLO-552	IGNITION CONTROL BOARD (ICB)
GLO-553	ICB FUSE 3.15 AMP, 250V
GLO-541	NG, GAS VALVE
GLO-542	LPG, GAS VALVE
GLO-581	STAINLESS STEEL HEAT EXCHANGER WITH MICROFUSE (NOT REPLACABLE)
GLO-543	FAN
GLO-44	LEAD, IONIZATION ELECTRODE CABLE
GLO-583	IONIZATION ELECTRODE
GLO-43	LEAD, IGNITION ELECTRODE CABLE
GLO-582	IGNITION ELECTRODE
GLO-49	IGNITION TRANSFORMER
GLO-301	IGNITION TRANSFORMER MOUNTING BRACKET

Acronym	
T_DCW	DOMESTIC COLD WATER TEMP
T_HEX_OUT	HEAT EXCHNAGER OUTLET WATER TEMP
T_DHW_OUT	DOMESTIC HOT WATER TEMP

# Warranty

**Glow Brand** warrants this product against failure due to defect in materials or workmanship under normal use and maintenance for a period of 60 months (5 years) or 65 months if the date of installation cannot be determined, and commences on the date of installation or commissioning of the appliance. Should any part fail during the applicable warranty period, **Glow Brand** will provide a new or remanufactured part to replace the defective part. Proof of purchase and installation date will be required in order to facilitate the warranty requirements. All parts claimed under warranty are to be returned to **Glow Brand** for testing and verification. The customer's account will be credited only after the defective part has been examined by **Glow Brand** or the vendor and determined to be defective. The cost of returning the goods to **Glow Brand** is by others. All warranty parts are to be prepaid by the customer. Warranty will not be offered until the equipment is paid for in full. Warranty on all equipment sold to customers may be suspended, at **Glow Brand's** discretion, until the customer's account is in good standing. Warranty covers defective components only. Normal wear and abuse is not covered. This warranty does not cover costs incurred for diagnosing, repairing, removing, installing, shipping, servicing, or handling of either failed parts, or replacement parts, or new units.

## SECOND THROUGH THE TENTH YEAR

Limited Warranty for the Stainless Steel Tube Heat Exchanger

**Glow Brand** warrants its stainless steel heat exchanger against failure due to defect in materials or workmanship under normal use and maintenance from the date of installation for the second through the tenth year to the original purchaser only. If during such time period, any part of the stainless steel tube heat exchanger is found to be defective, **Glow Brand** will provide replacement for the original heat exchanger.

## FIRST YEAR (Labor)

Labor Warranty for **Glow Brand** Tankless Condensing Water Heater

**Glow Brand** will provide a predetermined fixed labor amount for the replacement of defective parts for 1 year (12 months) and commences on the initial date of installation or commissioning of the appliance.

	Application	Heat Exchanger	Parts	Labor
Residential	Standard or Controlled Recirculation	10 years	5 years	1 year
	Uncontrolled Recirculation	5 years	3 years	1 year
Commercial	Standard or Controlled Recirculation	5 years	3 years	1 year
	Uncontrolled Recirculation	5 years	3 years	1 year

**Standard** - The Glow Brand unit is used as intended without the addition of a recirculation system.

**Controlled Recirculation** - The Glow Brand unit is used in conjunction with a recirculation pump as stated in the manual utilizing an aquastat or timer operating in non-continuous mode.

**Uncontrolled Recirculation** - The Glow Brand unit is used in conjunction with a recirculation pump as stated in the manual operating in continuous mode.

**Product Improvements** - As Glow Brand Technologies maintains a continuous improvement policy, specifications are subject to change without notice.

... continued

## Limitations on Liability

### This Warranty Does Not Cover

1. Installations by other than licensed plumber, gas installer or heating contractor.
2. Commissioning other than by a **Glow Brand** certified contractor.
3. Installations of equipment for other purposes than those intended by the instructions supplied with this equipment.
4. Installations of equipment for purposes other than domestic hot water production and central heating needs if installed.
5. Any product which is improperly installed or moved from its original place of installation.
6. Any product which has been repaired or replaced with other than **Glow Brand** factory parts.
7. Any product modified in any way, misused or damaged or which has been used contrary to the warrantor's written instructions.
8. Introduction of liquids other than potable water into this product.
9. Any damage to the product caused by failure to maintain the unit properly, improper voltage, improper gas pressure, improper water pressure, flood, freezing, electrical surges, fire, lightning, or Acts of God.
10. Nicks, scratches or discoloration of decorative finishes.
11. Installation, plumbing, gas piping and wiring not integral to the product.
12. Any **Glow Brand** product installed in an improper environment (e.g. Corrosive, dusty, and or chemically contaminated).
13. Condensate damage due to improperly installed or lack of a condensate trap (drain).
14. Damages due to accidents, abuse, misuse, improper installations, misapplication or incorrect sizing and lack of regular recommended maintenance.
15. The water heater is installed outdoors.
16. Failures resulting in the **Glow Brand** unit not being properly maintained as per the recommended maintenance.
17. Failures not reported to **Glow Brand** within the time period specified above.
18. Products damaged in shipment or storage or otherwise without fault of **Glow Brand**.
19. The water heater has not been installed in accordance with all applicable local plumbing and/or building code and/or regulations or in their absence with the latest edition of the natural gas and propane installation code and/or the National Electrical Code or Canadian Electrical code.
20. This warranty does not cover any expenses related to the removal or re-installation process. The homeowner will be responsible for the cost of removing and re-installing the alleged defective part or its replacement and all labor and material connected therewith, and transportation to and from **Glow Brand**.
21. The warranty cannot be considered as a guarantee of workmanship of an installer connected with the installation of the condensing water heater or as imposing a liability of any nature for unsatisfactory performance as a result of faulty workmanship in the installation, which liability is expressly disclaimed.

### Exclusion of Incidental and Consequential Damages/ Disclaimers

**Glow Brand** Technologies Inc. will not pay in contract or in tort, consequential or incidental damages under this warranty, both of which are specifically excluded. This means we shall not be responsible for any loss, expense or damage caused by any defect in the water heater, other than the water heater itself. The maximum liability of **Glow Brand** in connection with this limited warranty shall not in any case exceed price of the part claimed to be defective, or price of the water heater if the entire water heater is claimed to be defective. "Incidental" damages include expenses of inspection, obtaining substitute goods, transportation, etc. "Consequential" damages include injury to persons or property inconvenience or other consequential damage resulting from a breach of warranty.

### Owner Responsibilities

This Warranty is issued to the original purchaser only. This product must be used and cared for in accordance with the instruction manual. You are responsible for required periodic maintenance or service. See your instruction manual for details. You must be able to verify the installation date of the product against which you make and warranty claim. The original bill of sale, installer's invoice or other similar document is required to verify warranty. If you cannot show evidence of the actual date of installation, warranty coverage shall be extended to a total to 65 months from when the unit was manufactured. The attached Warranty Registration Form must be filled out completely and returned to **Glow Brand**. Failure to do so will prevent or delay our being able to contact you (or the person residing at this address) in case of a recall or important product safety alert. Your warranty



Warranty Registration Form  
info@glowbrand.ca

**PLEASE COMPLETE THE FOLLOWING INFORMATION  
RETURN WITHIN 30 DAYS OF COMMISSIONING  
THE APPLIANCE (HOT WATER HEATER)**

**Please Print Clearly**

**Sold To:**

Homeowner's Name: \_\_\_\_\_

Address: \_\_\_\_\_ Unit #: \_\_\_\_\_

City: \_\_\_\_\_ Province: \_\_\_\_\_ Postal Code: \_\_\_\_\_

Phone No. \_\_\_\_\_ Fax: \_\_\_\_\_

Email Address: \_\_\_\_\_

**Item Purchased:**

Unit Model: \_\_\_\_\_ Serial No. \_\_\_\_\_

Date of Purchase: \_\_\_\_\_ Date of Startup: \_\_\_\_\_

**Purchased From:**

Installing Contractor's Name: \_\_\_\_\_

Address: \_\_\_\_\_ City: \_\_\_\_\_

Phone No. \_\_\_\_\_ Province: \_\_\_\_\_ Postal Code: \_\_\_\_\_

Email Address: \_\_\_\_\_ Fax: \_\_\_\_\_

Signature: \_\_\_\_\_ Date: \_\_\_\_\_

Please complete and return this form to Glow Brand.  
ATTENTION: Product Registration.







Please complete the following information and return it with the part request

**Contractor / Distributor / Rental Provider Name:** \_\_\_\_\_ **Date:** \_\_\_\_\_

Address: \_\_\_\_\_ Unit # \_\_\_\_\_

City: \_\_\_\_\_ Prov. \_\_\_\_\_ Postal Code: \_\_\_\_\_

Phone # \_\_\_\_\_ Other # \_\_\_\_\_

Email: \_\_\_\_\_

**Homeowner Name:** \_\_\_\_\_

Address: \_\_\_\_\_ Unit # \_\_\_\_\_

City: \_\_\_\_\_ Prov. \_\_\_\_\_ Postal Code: \_\_\_\_\_

Phone # \_\_\_\_\_ Other # \_\_\_\_\_

Email: \_\_\_\_\_

**Model Number:** \_\_\_\_\_ **Serial number:** \_\_\_\_\_

**Date installed:** \_\_\_\_\_ **Date Failed:** \_\_\_\_\_ **Date Serviced:** \_\_\_\_\_

**Failed Part Number:** \_\_\_\_\_ **Replacement Part Number:** \_\_\_\_\_

**Failed Part Description:** \_\_\_\_\_

**Reason for Failure:** \_\_\_\_\_

\_\_\_\_\_  
\_\_\_\_\_  
\_\_\_\_\_  
\_\_\_\_\_  
\_\_\_\_\_  
\_\_\_\_\_

**“FAILED, NOT WORKING, DEFECTIVE” etc.,  
is not acceptable and will be considered incomplete.  
Incomplete warranty forms will not be accepted or considered. Only a detailed  
explanation will be considered for warranty.  
All parts returned must be accompanied with a completed warranty tag.**





# WATER HEATER COMMISSIONING SHEET

DATE:

Model #:

Serial #:

INSTALLATION DATE:

BUILDER/SITE NAME:		BLK / LOT #
HOMEOWNER NAME:		TEL:
ADDRESS:		CELL:
CITY:	POSTAL CODE:	OTH:

CONTRACTOR NAME:		TEL:
ADDRESS:		CELL:
CITY:	POSTAL CODE:	FAX:
Technician:	EMAIL:	

**Prior to commencing any commissioning, Hydro, Gas and Water must be available at the Glow T180 unit**

PROCEDURE	READING	REMARKS
Verify that the unit being installed matches the work order		
Ensure the venting complies with the installation manual & local codes		
Ensure a minimum 24" clearance from the appliance front is maintained		
Check for correct voltage & polarity		
Verify that all gas and water connections are tight and leak free		
Check the gas pressure at the appliance (min. 3.5" wc Nat / 8" wc Lp)		
Ensure the pressure relief is installed and operating properly		
Ensure the drain tube and condensate hose are properly installed		
Check that the condensate trap has been primed and is not obstructed		
Inspect and verify the safety components are operating as intended		
Bleed all the air from the heating loop / recirculation line if equipped		
Verify the outlet water temperature is set to 120°F / 49°C		
Ensure the installation manual is left with the appliance		
Check the Glow T180's CO <sub>2</sub> % complies with values listed in the installation manual	NATURAL GAS, (CO <sub>2</sub> %)	
	LIQUID PROPANE (CO <sub>2</sub> %)	

**Check that there is no flammable material or liquids in the immediate vicinity of the appliance**

<b>ADDITIONAL COMMENTS</b>

I confirm that the information listed on this commissioning sheet is a true and accurate account of what has been completed.

TECHNICIAN SIGNATURE: \_\_\_\_\_

209 Citation Drive, Concord Ontario L4K 2Y8. Tel: 905-264-1414, Fax: 905-264-1147  
 Email: [info@glowbrand.ca](mailto:info@glowbrand.ca) Website: [www.glowbrand.ca](http://www.glowbrand.ca)





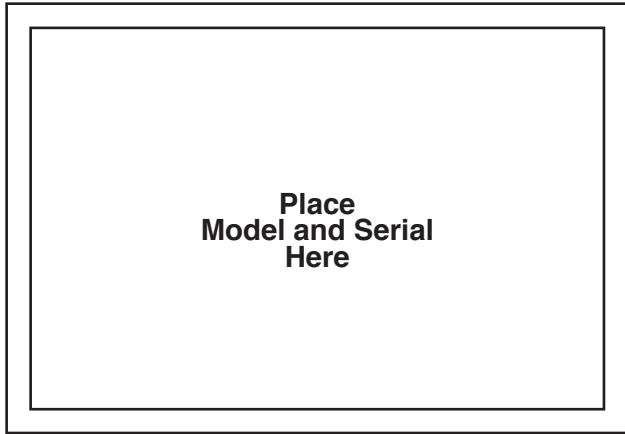

## *Instruction & Installation Manual*

*Model*

# **Glow T180** *Tankless Condensing Water Heater* *188,000 BTU*

### **Getting Service**

1. When you contact Technical Support, please have the following information at hand.
2. Model Number
3. Serial Number
4. Date Purchased
5. Installation location and type
6. Error code, if any appears on the front display.



209 Citation Drive, Concorde Ontario L4K 2Y8  
Telephone: 905-264-1414  
Fax: 905-264-1147  
Email: [info@glowbrand.ca](mailto:info@glowbrand.ca)  
Website: [www.glowbrand.ca](http://www.glowbrand.ca)