



Glow
Brand™

SUBMITTAL DATA SHEET

Job Name:		Contractor:	
Location:		Distributor:	
Engineer:		Date:	
Submitted To:		Model No:	T-180 NG T-180 LP
Schedule ID:		Unit Quantity:	

Specification	Natural Gas	Propane
Heat Input - Max. Btuh(kW)	194,000 (56.8)	194,000 (56.8)
Heat Input - Min. Btuh(kW)	20,500 (6.0)	20,500 (6.0)
Energy Factor (EF)	97%	95%
Unified Energy Factor (UEF)	95%	93%
Heat output - Max. Btuh(kW)	188,000 (55.1)	188,000 (55.1)
Hot Water Temperature Setting - Min-Max ° F (° C)	102-145 (39-63)	
Water Pressure - Max. Psig (bar)	150 (10.3)	
Water Pressure - Min. Psig (bar)	30 (2.1)	
DHW Flow @ ΔT 35 °F USgpm (lpm)	10.7 (40.2)	
DHW Flow @ ΔT 45 °F USgpm (lpm)	8.4 (31.8)	
DHW Flow @ ΔT 72 °F USgpm (lpm)	5.2 (19.7)	
DHW Flow @ ΔT 77 °F USgpm (lpm)	4.9 (18.6)	
Min. Activation Flow Rate USgpm (lpm)	0.6 (2.27)	
Power (120Vac/60Hz) - Watts @ full fire	119	
Cold Water In Connection - MPT, in.	3/4	
Hot Water Out Connection - MPT, in.	3/4	
Gas Inlet Connection - MPT, in.	3/4	
Inlet Pressure - Min. inch w.c.	3.5	8
Inlet Pressure- Max. inch w.c.	10	13
Gas Valve Outlet Pressure inch w.c.	-0.03	
Vent/Air-Intake Pipe Diameter, inches (mm)	2 (51) or 2 ½ (63.5) or 3 (76)	
Max equivalent vent length 2" (each side) - ft	25	
Max equivalent vent length 2 ½" (each side) - ft	50	
Max equivalent vent length 3" (each side)- ft	100	
Vent Clearances inches (mm)	0 to combustibles	
Exhaust Venting Material	PVC or CPVC	
Intake Venting Material	PVC or CPVC or ABS	
Dimensions H x W x D - inches (mm)	24.38 x 16.75 x 17.25 (619 x 425 x 438)	
Weight (empty) - lbs (Kg)	86 (39)	

FEATURES

Stainless Steel Heat Exchanger and Burner, Fully Modulating 10:1 Turn Down Ratio, ECM Fan Motor, PVC Venting, 10 Year Heat Exchanger Warranty, ECO and Comfort Modes, Energy Star Certified, NSF Certified.

SUPPLIED ACCESSORIES

150 psi Pressure Safety Relief Valve, Birdscreens, Condensate Connection Adapter

OPTIONAL ACCESSORIES

Quantity	PART No	Description
	140-103	Recirculation Pump UPS15-55SUC/TLC w/Timer
	529913	½" Sweat Connect Kit w/Check Valve (for use with 140-103)
	529911	¾" Sweat Connect Kit w/Check Valve (for use with 140-103)
	140-003	Recirculation Pump UPS15-58
	96806141	½" Sweat Connect Kit w/Check Valve (for use with 140-003)
	96806143	¾" Sweat Connect Kit w/Check Valve (for use with 140-003)
	GLO-180-80	High Temperature Aquastat (105 ° F/ 10 ° F Diff)
	GLO-103-01	Bypass Valve
	GLO-103-02	½" x ½" Flex Braid Hose Kit (2 pcs)
	GLO-103-03	¾" x ½" Flex Braid Hose Kit (2 pcs)

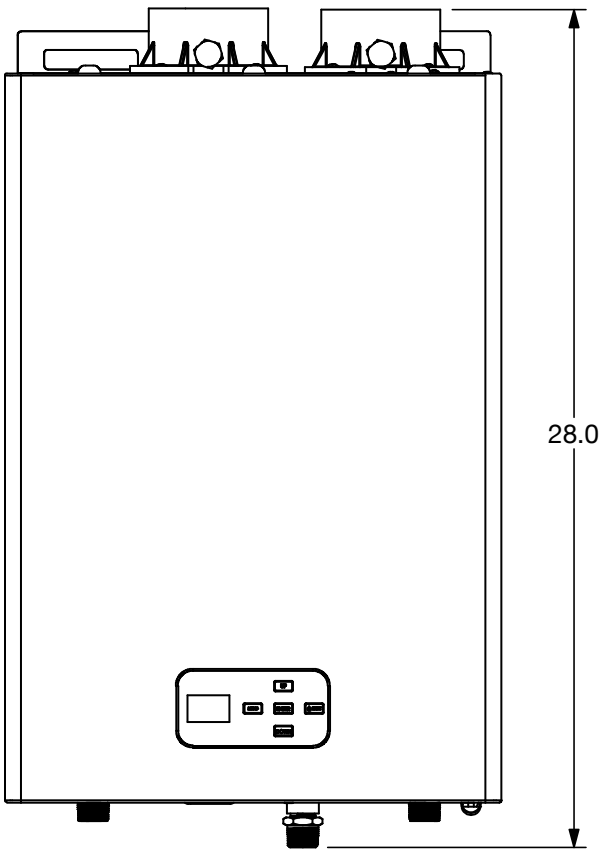

Glow T-180 Dimensions

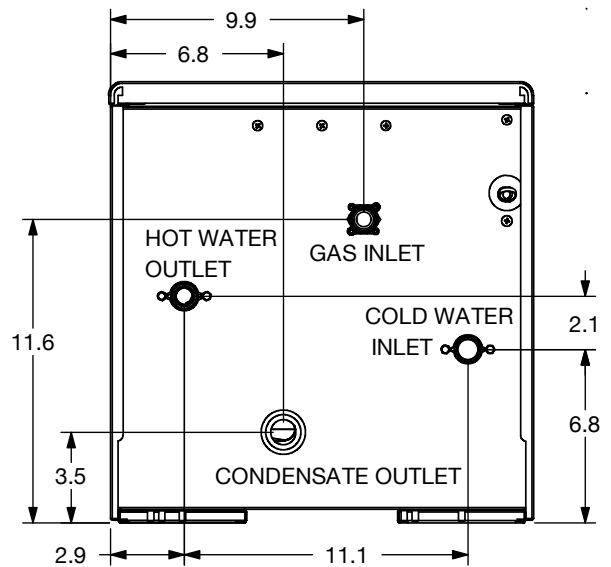
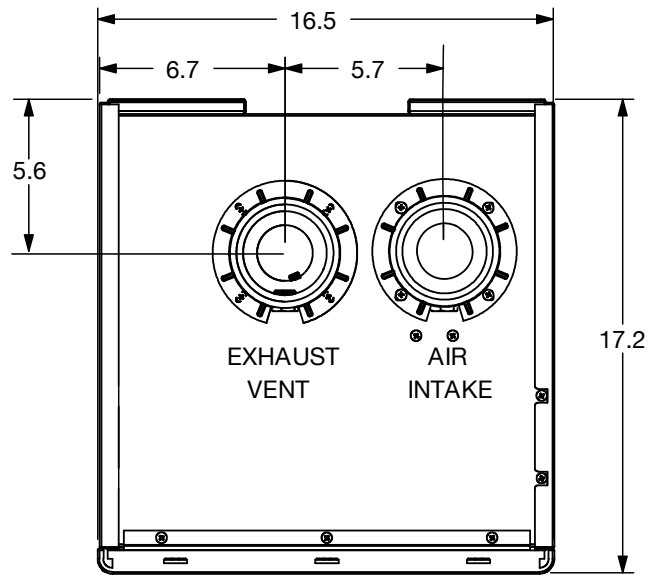

Legend	
Gas Inlet	Ø 3/4" NPT
Cold Water Inlet	Ø 3/4" NPT
Hot Water Outlet	Ø 3/4" NPT
Condensate Outlet	Ø 3/4" I.D

Notes: